

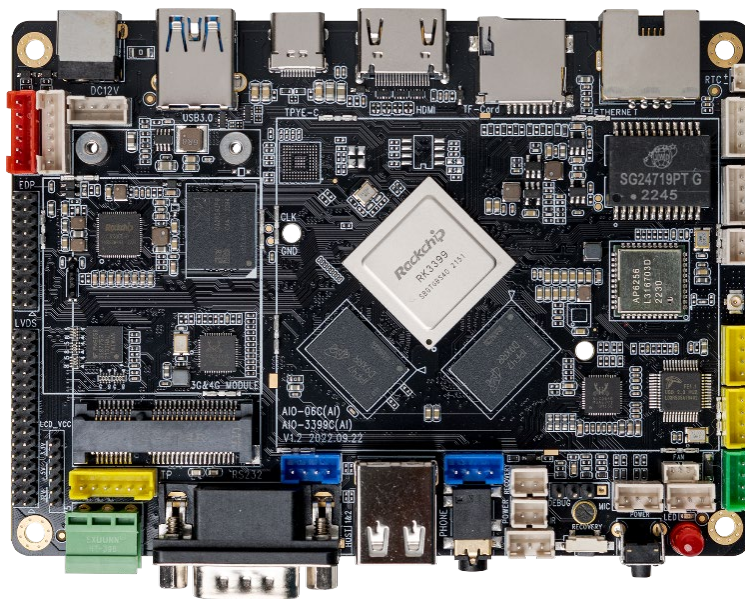

# AIO-3399C(AI)

Hexa-core 64-bit AI Mainboard



V1.2 2025-4-2

T-CHIP INTELLIGENCE TECHNOLOGY



## Directory

1. Product Overview.....	3
2. Specification.....	4
3. Interface description.....	5
4. PCB Size.....	6
5. Product Customize.....	7
6. Interface definition.....	8
6.1 LVDS.....	8
6.2 EDP.....	9
6.3 BL_CTL.....	10
6.4 GPIO.....	10
6.5 TP.....	11
7. Industrial-grade case.....	12
8. About us.....	12



# 1. Product Overview

It adapts 64-bit six-core processor, with powerful hardware decoding capabilities and supporting 4K hardware decoding. Featuring a variety of display output interfaces, it can directly drive multiple resolutions eDP interface LCD screen.

Main characteristics:

## 1. Six-core 64-bit High-performance Processor

Adopts RK3399 six-core 64-bit (A72x2+A53x4) high-performance processor, frequency up to 1.8GHz, integrated quad-core ARM high-end GPU Mali-T860. Provide a variety of storage configuration options, users only need to expand the function backplane to quickly achieve project development.

## 2. Rich Extension Interfaces

AIO-3399C can be powered by POE+ (802.3 AT, output power 30W) enhanced Ethernet. It has rich external interfaces, supports RS232, RS485 interface, and onboard 2-way UART, convenient to connect various industrial equipment and easy to achieve product development.

## 3. Powerful Hardware Decoding Capability

It supports dual LVDS, EDP, HDMI and other display output interfaces, dual-screen identical display/dual-screen differential display, and H.265 HEVC, VP9 and H.264 encoding, 4K HDR, maximum support for 4K hardware decoding. AIO-3399C can directly drive multiple resolutions eDP interface LCD screen.

## 4. Open Source

Complete with SDK, tutorial, technical information and development tools can be downloaded on the website , making development and learning easier.

## 5. Application

It is suitable for cluster servers, high-performance computing/storage, computer vision, gaming equipment, commercial display equipment, medical equipment, vending machines, industrial computers, etc.



## 2. Specification

Basic Specifications	
SOC	Rockchip RK3399 (28nm HKMG Process)
CPU	Six-Core ARM 64-bit processor, up to 1.8GHz Based on Big.Little architecture, Dual-Core Cortex-A72 and Quad-Core Cortex-A53 with separate NEON coprocessor
GPU	ARM® Mali-T860 MP4 Quad-core GPU Support OpenGL ES1.1/2.0/3.0/3.1, OpenVG1.1, OpenCL, DX11 Support AFBC(frame buffer compression)
VPU	Support 4K VP9 and 4K 10bits H265/H264 video decoding, up to 60fps 1080P multi-format video decoding (WMV, MPEG-1/2/4, VP8) 1080P video coding, support H.264, VP8 format Video post processor, de-interlacing, de-noising, edge/detail/color optimization
RAM	2GB/4GB Dual-Channel LPDDR4
Storage	8GB high-speed eMMC 5.1 (8GB/16GB/32GB/128GB) Support TF Card Extended Storage
Power	With a one-way infrared receiver Support infrared remote control DC 12V/2A(5.5 * 2.1mm, support 9V~24V wide voltage input) Support for external connection (Power 1 * socket) Can power by POE+ (802.3 AT, Output Power30W) Ethernet
Power consumption	Max: 14.3W(13V/1.1A), Normal: 8.4W(12V/0.7A), Min: 3.3W(11V/0.3A)
OS	Android, Linux+QT, Ubuntu
PCB Size	126 mm* 91.3mm
Environment	Work temperature: -20°C-60°C Storage temperature: -20°C~70°C Storage humidity: 10%~90%RH(non-condensing)
Interface Specifications	
Network	10 / 100 / 1000 Mbps Ethernet interface (RJ45) Support 2.4GHz / 5GHz dual-band WiFi, 802.11a/b/g/n/ac protocol Support Bluetooth 4.1 (support BLE) Mini PCIe (Used to expand 3G/4G modules, use with Micro SIM card slot)
Multimedia	Support 4K VP9 and 4K 10bits H265/H264 video decoding, up to 60fps 1080P Multi-format video decoding (VC-1, MPEG-1/2/4, VP8) Support the encoding of 1080P videos with H.264 and VP8 formats Video post processor: deinterlacing, denoising, edge/ detail/ color optimization Dual ISP pixel processing capability up to 13MPix/s, supports imultaneous input of two-way camera data
Display	Dual VOP: support 4096*2160 and 2560*1600 HDMI2.0 support 4K 60Hz display, support HDCP 1.4/2.2 Support DisplayPort 1.2 (4lines, Maximum support 4K 60Hz) Support eDP 1.3 (4 lines, 10.8Gbps), can directly drive multiple resolutions eDP Interface LCD screen Support dual 6/8-bit LVDS interface, up to 24-bit 1920*1200 resolution Support Rec.2020 and Rec.709 color gamut conversion
Audio	1 * 3.5mm Audio jack, 1 * LINE-IN, 1 * LINE-OUT, 1 * Microphone (left and right channel), 1 * Speaker
Serial port	1 * RS232, 1 * RS485, 1 * Debug serial port, 2 * UART(2-way TTL port)
USB	1 * Type-C (OTG), 1 * USB3.0, 4 * USB2.0(2 * interface, 2 * socket)
Other interface	1 * GPIO/SPI, 1 *LCD backlight, 1 * LCD_VCC jumper, 1 * TP, 1 * IR, 1 *Recovery, 1 * RTC, 1 * ADC, 1 * I2C, 1 * I2S, 1 * Fan(3P-1.25mm), 1 * Gravity sensor(Scalable), 1 * SIM Card



### 3.Interface description

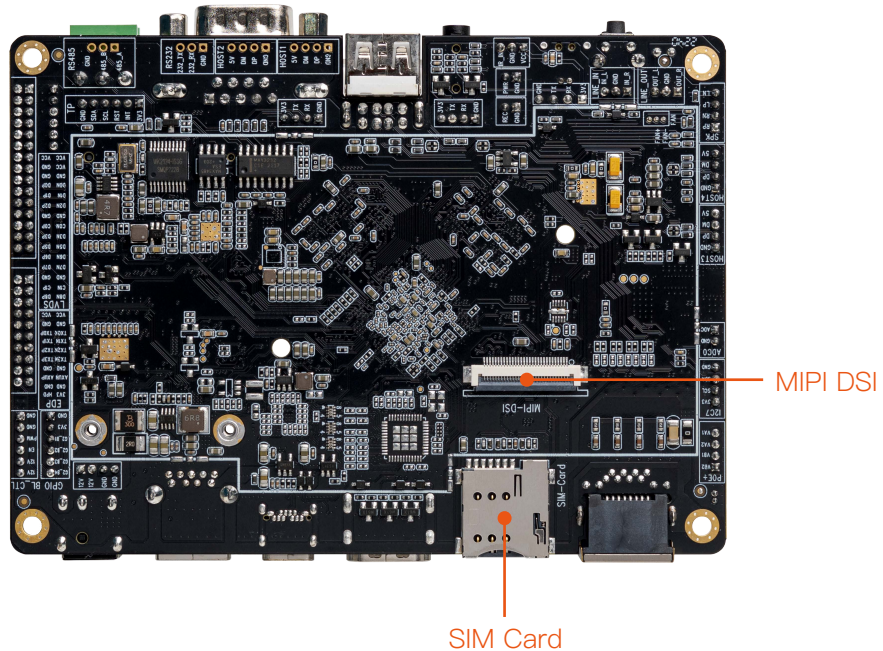
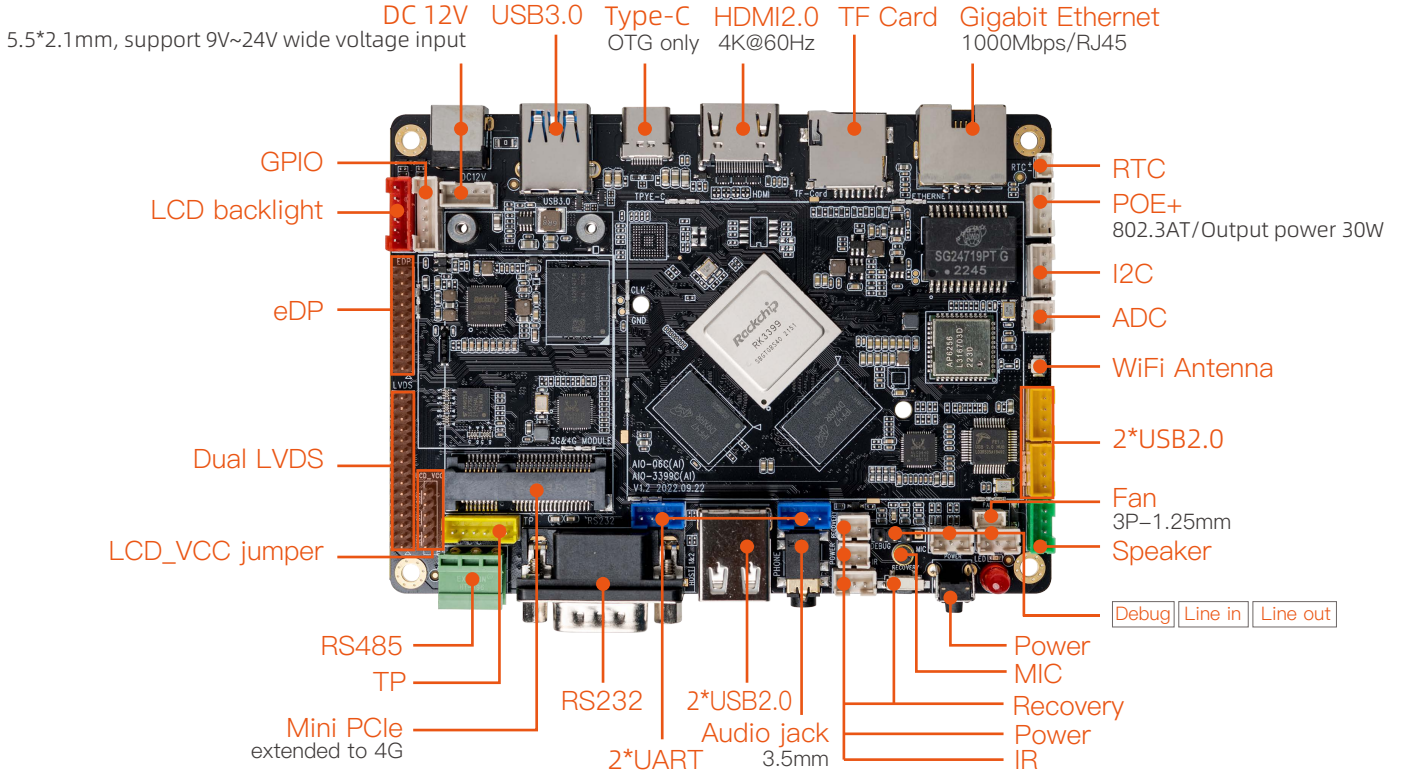



## 4.PCB Size

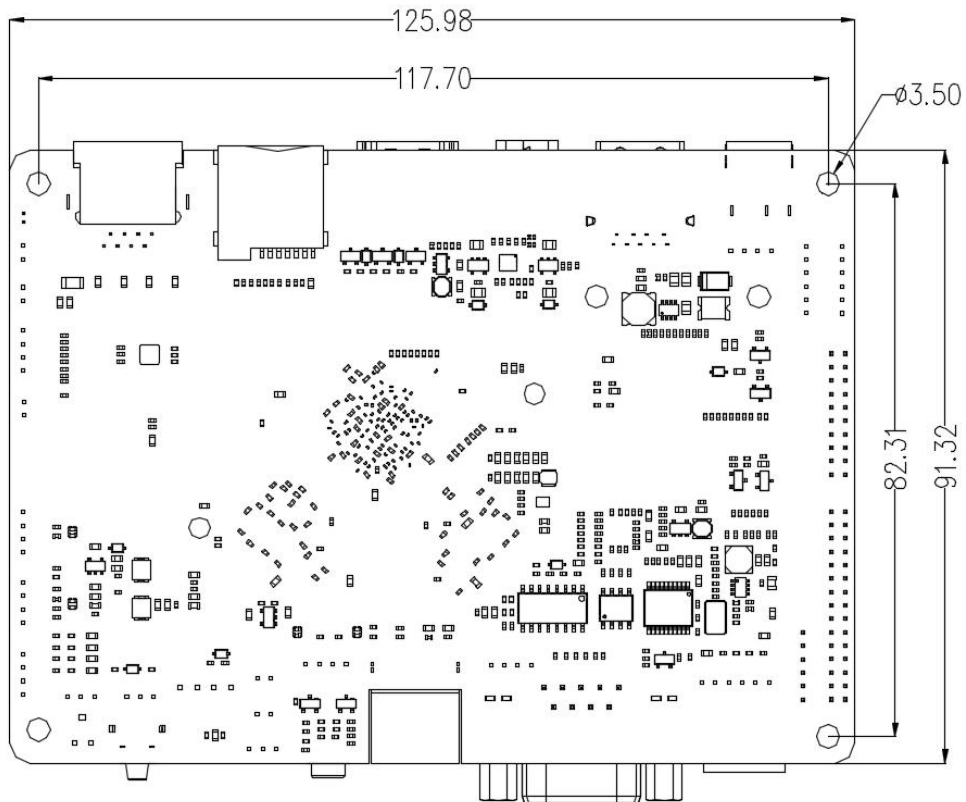

## 5. Product Customize

The interface of Mainboard can be customized according to customer's requirements

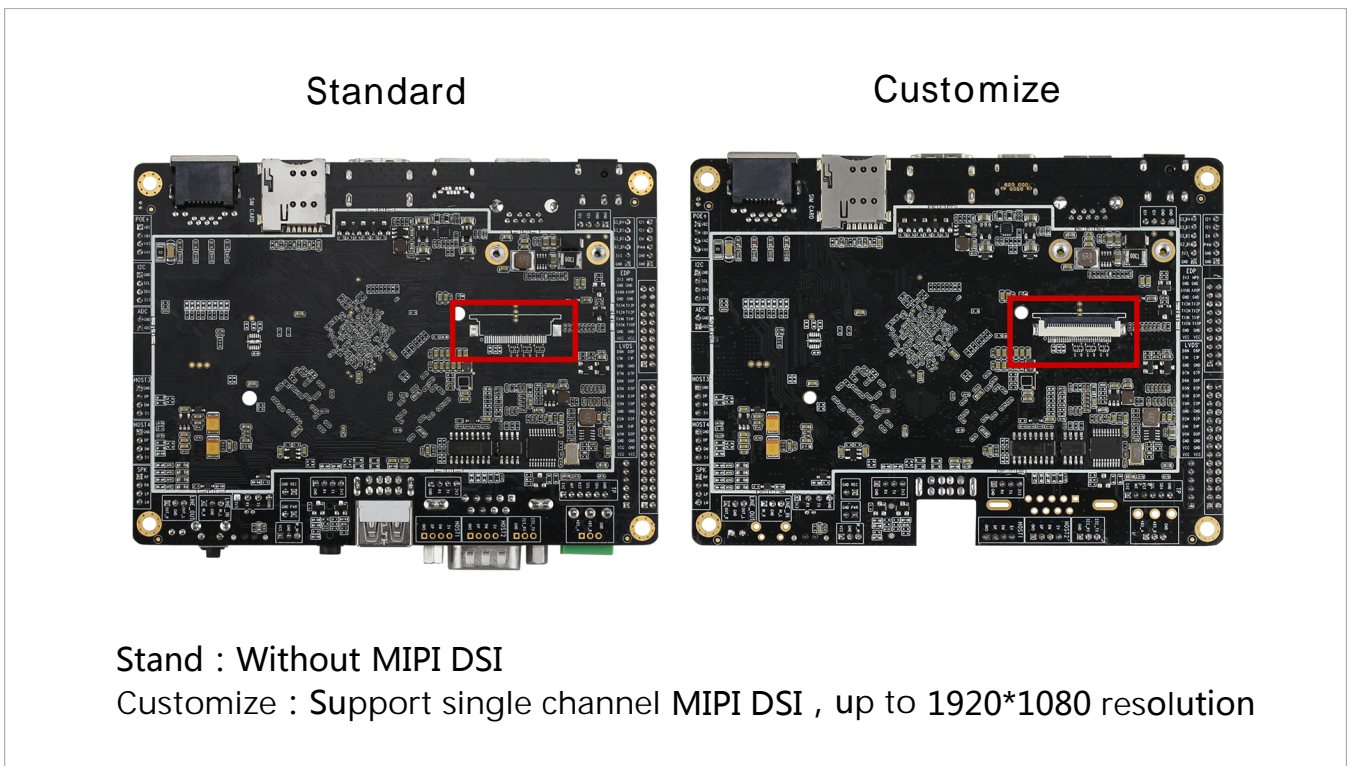
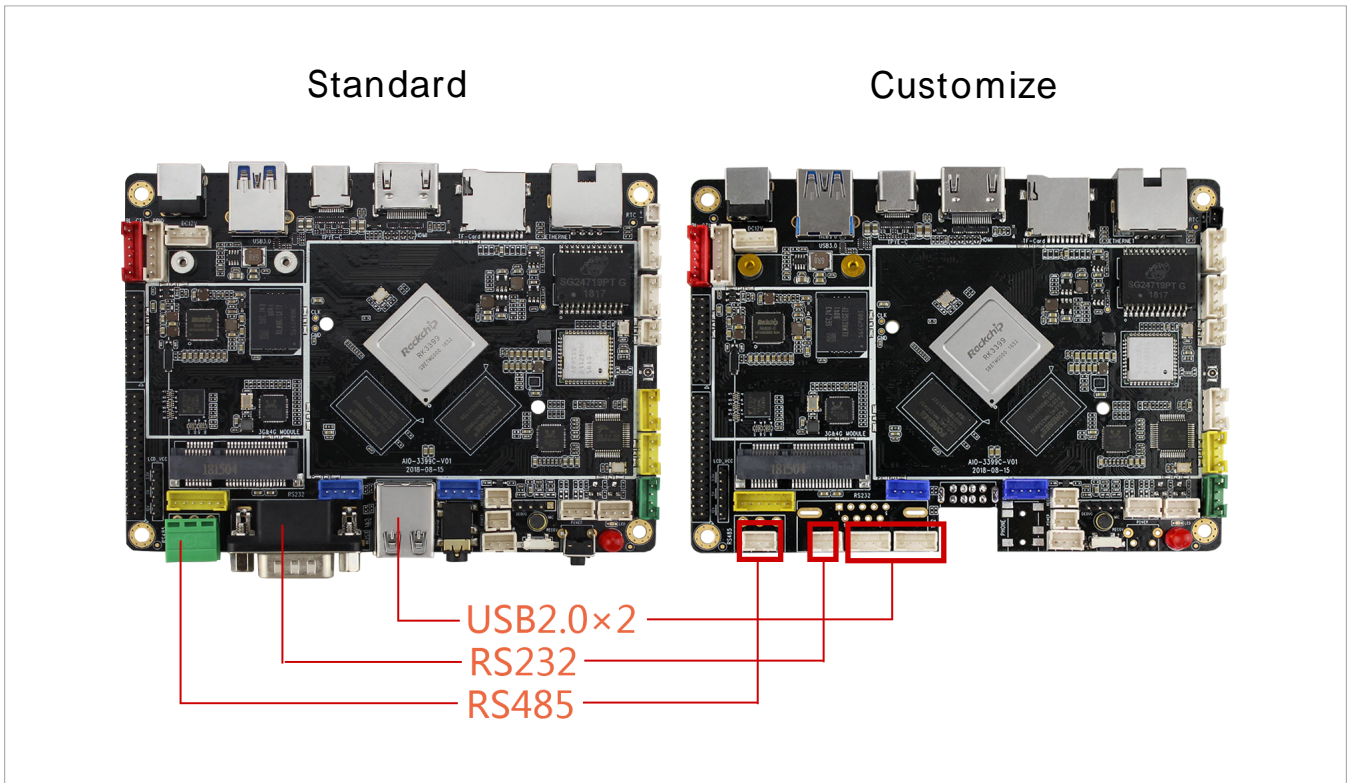



## 6. Interface definition

### 1. LVDS double row 30PIN 2.0 pitch interface (GPIO)

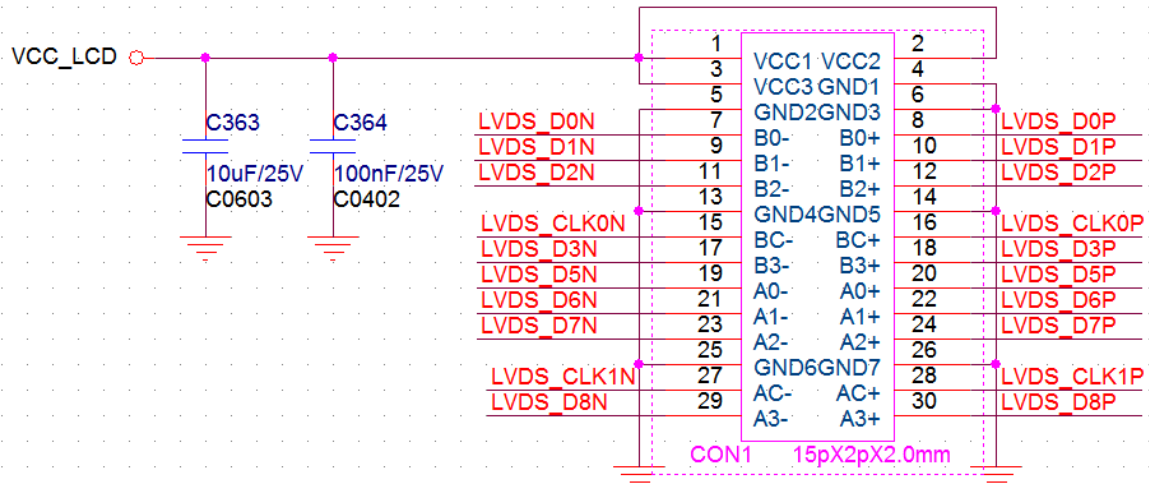

NO.	Definition	NO.	Definition
1	VCC_LCD	2	VCC_LCD
3	VCC_LCD	4	GND
5	GND	6	GND
7	LVTX1AN	8	LVTX1AP
9	LVTX1BN	10	LVTX1BP
11	LVTX1CN	12	LVTX1CP
13	GND	14	GND
15	LVTX1DN	16	LVTX1DP
17	LVTX1EN	18	LVTX1EP
19	LVTX2AN	20	LVTX2AP
21	LVTX2BN	22	LVTX2BP
23	LVTX2CN	24	LVTX2CP
25	GND	26	GND
27	LVTX2DN	28	LVTX2DP
29	LVTX2EN	30	LVTX2EP



## 2. EDP double row 30PIN 2.0 pitch interface (GPIO)

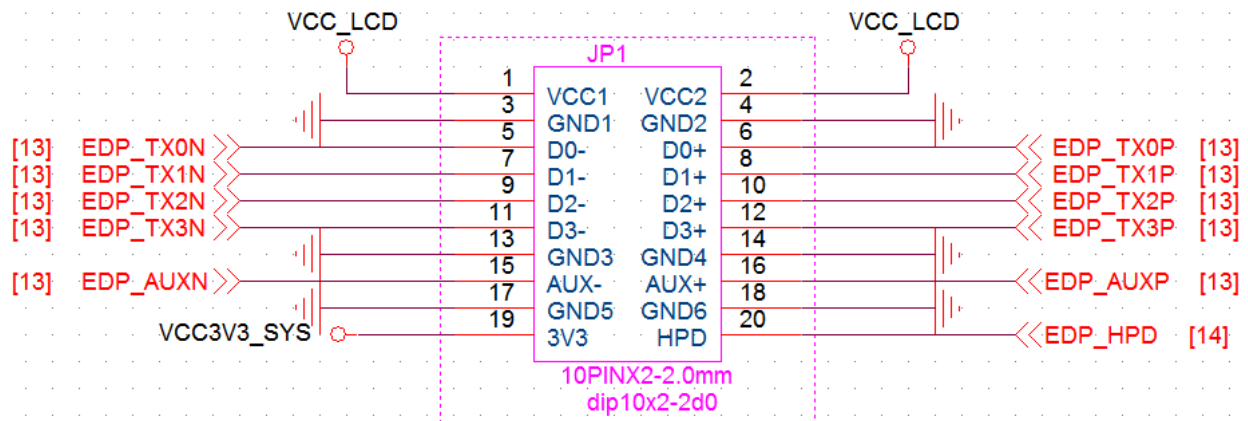

NO.	Definition	NO.	Definition
1	VCC_LCD	2	VCC_LCD
3	GND	4	GND
5	EDP_TX0N	6	EDP_TX0P
7	EDP_TX1N	8	EDP_TX1P
9	EDP_TX2N	10	EDP_TX2P
11	EDP_TX3N	12	EDP_TX3P
13	GND	14	GND
15	EDP_AUXN	16	EDP_AUXP
17	GND	18	GND
19	VCC3V3_SYS	20	EDP_HPD

### 3. BL\_CTL single row 6PIN 2.0 pitch interface (GPIO)

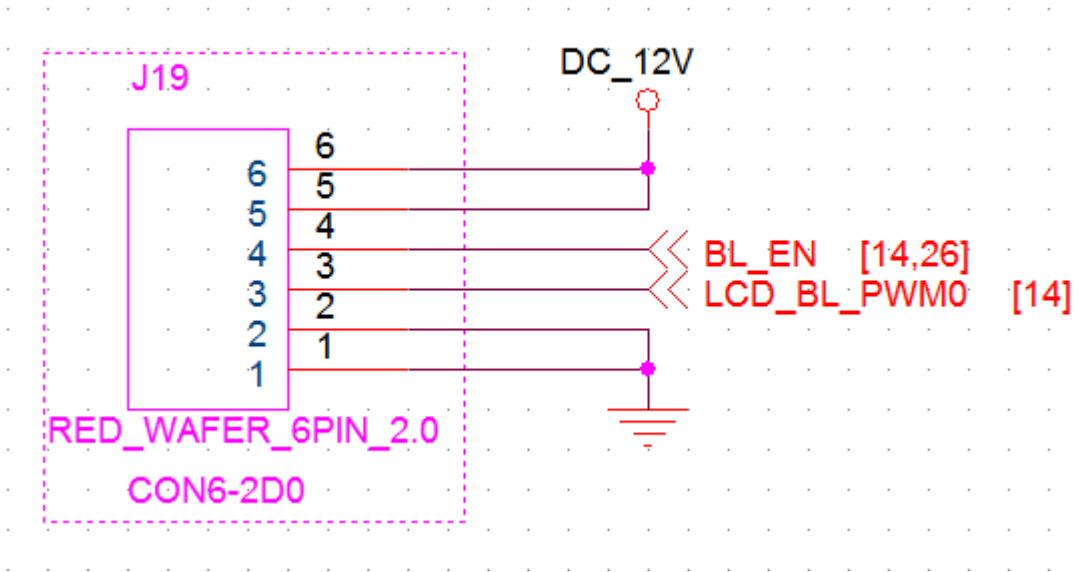

NO.	Definition
1	GND
2	GND
3	GPIO4_C2/PWM0/VOP0_PWM/VOP1PWM
4	GPIO1_A1/ISP0_SHUTTER_TRIG/ISP1_SHUTTER_TRIG/TCPD_CC0_VCONN_EN
5	DC_12V
6	DC_12V

### 4. GPIO single row 6 PIN 2.0 pitch interface

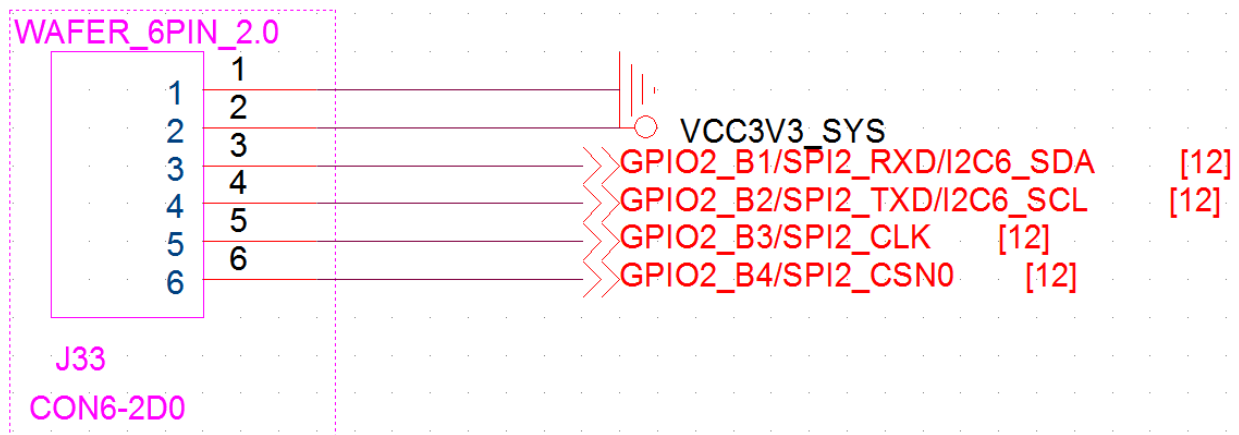

NO.	Definition
1	GND
2	VCC3V3_SYS
3	GPIO2_B1/SPI2_RXD/CIF_HREF/I2C6_SDA
4	GPIO2_B2/SPI2_TXD/CIF_CLKIN/I2C6_SCL
5	GPIO2_B3/SPI2_CLK/VOP_DEN/CIF_CLKOUTA
6	GPIO2_B4/SPI2_CSN0

### 5. TP single row 6 PIN 2.0 pitch interface (GPIO)

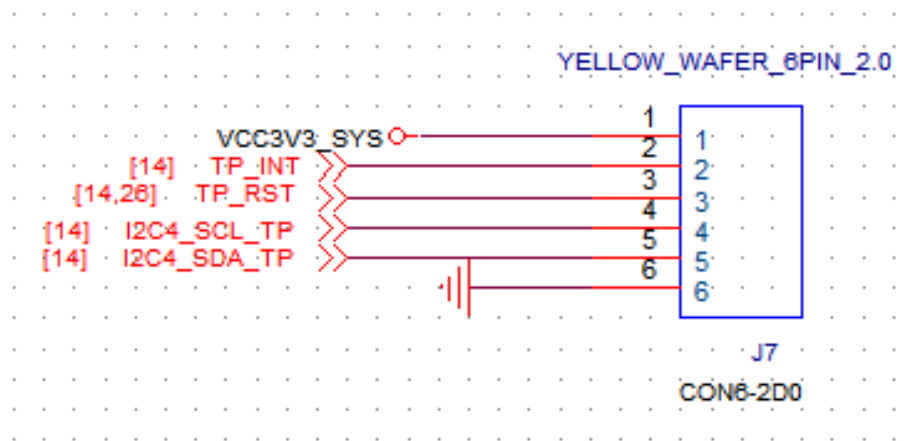

NO.	Definition
1	VCC3V3_SYS
2	GPIO4_D4
3	GPIO4_C5/SPDIF_TX
4	GPIO1_B4/I2C4_SCL
5	GPIO1_B3/I2C4_SDA
6	GND

## 7.Industrial-grade case

Equipped with industrial grade metal casing, featuring small size, fanless efficient heat dissipation, dustproof and anti-disruption. It has various installation methods and can be flexibly embedded in various smart devices.

[Click to access "Six-core 64-bit AI Embedded Computer"](#)





## T-CHIP INTELLIGENCE TECHNOLOGY

---



Contact Us  
(+86)18688117175



E-mail  
[global@t-firefly.com](mailto:global@t-firefly.com)



Website  
<https://en.t-firefly.com/>



Address  
Room 2101, Hongyu Building, #57 Zhongshan 4Rd, East District,  
Zhongshan, Guangdong, China.