



EC-A3588JD4

| AI Large-model Computer

V1.0 2025-5-13

T-CHIP INTELLIGENCE TECHNOLOGY





Product features



A new generation of flagship AIoT chip RK3588

Adopting Rockchip's new flagship AIoT chip RK3588, 8nm LP process. It is equipped with an octa-core 64-bit CPU with a frequency of up to 2.4GHz. Integrated ARM Mali-G610 MP4 quad core GPU, built-in AI accelerator NPU, can provide 6TOPS computing power.



8K HD video decoding and encoding

Supports 8K@60fps H.265/VP9, 8K@30fps H.264 video decoding, and 8K@30fps H.265/H.264 video encoding. Support the same compilation and interpretation.



The private deployment of large language models

Support the private deployment of ultra-large-scale parameter models under the Transformer architecture, including large language models such as Gemma-2B, ChatGLM3-6B, Qwen-1.8B, Phi-3-3.8B. Support Docker container management technology.



Multiple deep learning frameworks

It supports traditional network architectures such as CNN, RNN, and LSTM, and supports the import and export of RKNN models; Support a variety of deep learning frameworks, including TensorFlow, TensorFlow Lite, PyTorch, Caffe, ONNX and Darknet. It also supports the development of custom operators.



Product features



Various operating systems

Support Android and Linux OS, domestic operating system, and can support UEFI boot; Provide a safe and stable system environment for product research and production to meet the needs of different users.



Industrial-grade metal enclosure with efficient fanless passive cooling

The device features an industrial-grade, all-metal enclosure with an aluminum alloy structure for efficient heat dissipation. Its fanless design contributes to silent operation, ensuring 24/7 uninterrupted and stable performance.

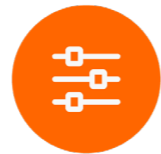

Abundant expansion interfaces

Equipped with HDMI2.1, PCIe2.0, USB3.0, RS485, RS232, CAN, TF Card, SIM Card, Type-C and other expansion interfaces, convenient for connecting various external devices.



A wide range of applications

It is widely used in: ARM PC, edge computing, cloud terminals, cloud servers, industrial control, artificial intelligence, large model privatization deployment, intelligent security and other fields.

Specifications



| Specifications | | |
|--------------------------|---|---|
| Basic Specifications | SOC | Rockchip RK3588 |
| | CPU | Octa-core 64-bit processor (4×Cortex-A76+4×Cortex-A55) , main frequency up to 2.4GHz |
| | GPU | ARM Mali-G610 MP4 quad-core GPU, support OpenGL ES3.2/OpenCL 2.2/Vulkan1.1, 450 GFLOPS |
| | NPU | The computing power is up to 6TOPS(INT8), support INT4/INT8/INT16 mixed operations |
| | ISP | Integrated 48MP ISP, support HDR and 3DNR |
| | Codecs | Hard Decoding: 8K@60fps H.265/VP9/AVS2, 8K@30fps H.264 AVC/MVC, 4K@60fps AV1, 1080P@60fps MPEG-2/-1/VC-1/VP8 Hard Encoding: 8K@30fps H.265/H.264 |
| | RAM | LPDDR4/LPDDR4x (4GB/8GB/16GB optional, up to 32GB) |
| | Storage | eMMC (32GB/64GB/128GB/256GB optional) |
| | Storage Expansion | M.2 SATA3.0/PCIe NVMe SSD 2242/2260/2280 (Inside the computer), 1 × TF Card |
| | OS | Android, Linux OS |
| | Software support | <ul style="list-style-type: none"> Support the privatization deployment of ultra-large-scale parametric models under the Transformer architecture, such as Gemma-2B, ChatGLM3-6B, Qwen-1.8B, Phi-3-3.8B and other large language models It supports traditional network architectures such as CNN, RNN, and LSTM, and supports the import and export of RKNN models; Support a variety of deep learning frameworks, including TensorFlow, TensorFlow Lite, PyTorch, Caffe, ONNX and Darknet. It also supports the development of custom operators Support Docker container management technology |
| | Power | DC 12V (5.5mm × 2.1mm, support 9V~24V wide voltage input) |
| | Size | 188.0mm × 88.44mm × 50.65mm |
| | Weight | Net weight of computer: 0.79kg, Total weight with package: 1.12kg |
| Environment | Operating Temperature: -20°C ~ 60°C, Storage Temperature: -20°C ~ 70°C, Storage Humidity: 10% ~ 90%RH(non-condensing) | |
| Interface Specifications | Internet | Ethernet: 2 × RJ45 (1000Mbps) WiFi: Extend WiFi/Bluetooth module through M.2 E-KEY (2230), support 2.4GHz/5GHz dual band WiFi6 (802.11a/b/g/n/ac/ax),Bluetooth5.2 4G: Extend 4G LTE via Mini PCIe (Reused with 5G) 5G: Extend 5G via M.2 B-KEY (Reused with 4G and USB3.0(1), not pasted by default) |
| | Video output | 1 × HDMI2.1 (8K@60fps or 4K@120fps) |
| | Audio output | 1 × 3.5mm Audio jack (Support MIC recording, American Standard CTIA) |
| | USB | 2 × USB3.0 (Max: 1A; UP: USB3.0(1), reused with 5G; DOWN: USB3.0(2)) |
| | Other interfaces | 1 × Type-C (OTG), 1 × SIM Card 1 × Phoenix connector (2×4PIN, 3.5mm pitch): 1 × RS485, 1 × RS232, 1 × CAN 2.0 |

Interface description

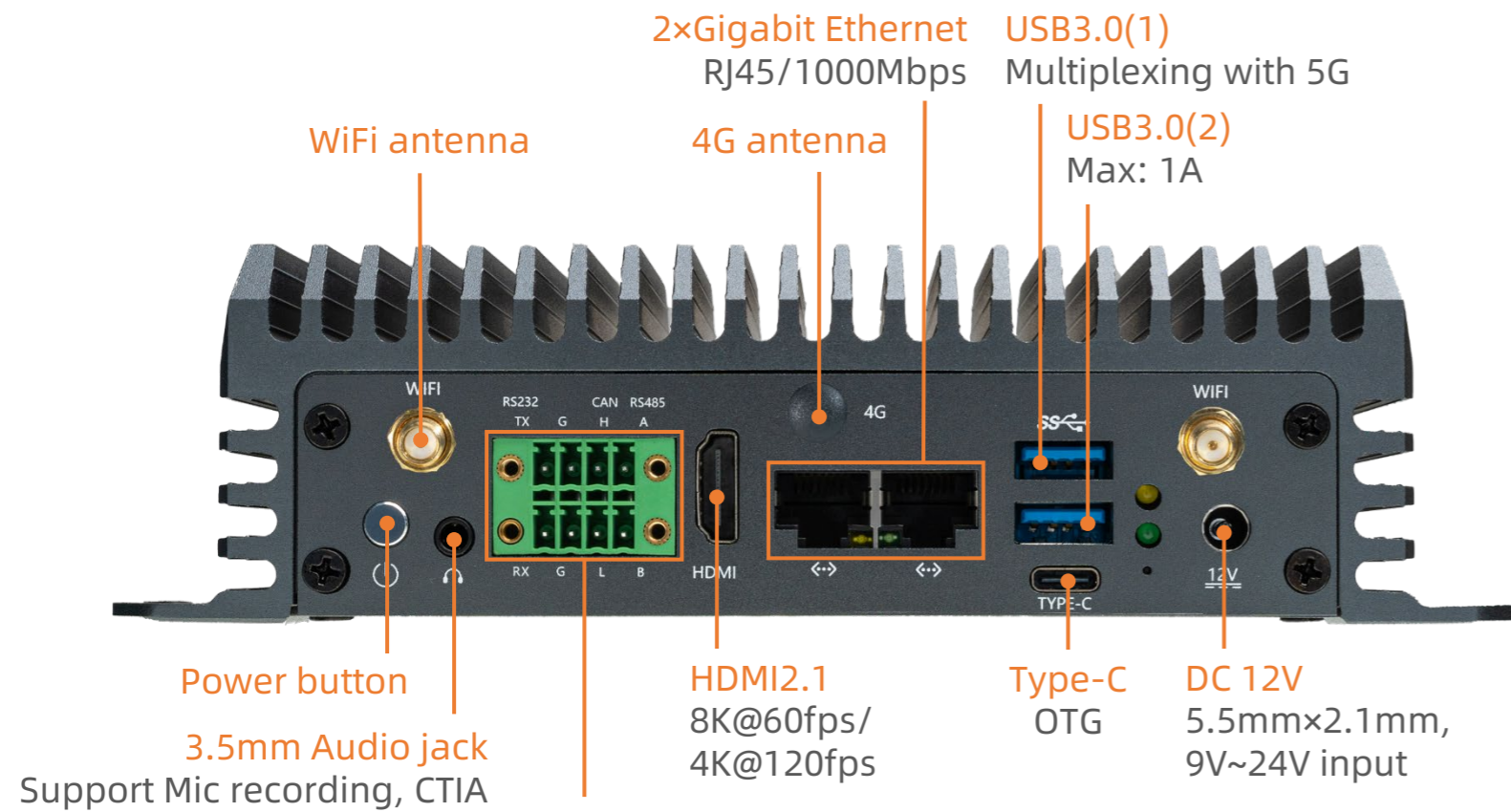

| | | | |
|--------|-----|-------|-------|
| 232-TX | GND | CAN_H | 485_A |
| 232-RX | GND | CAN_L | 485_B |

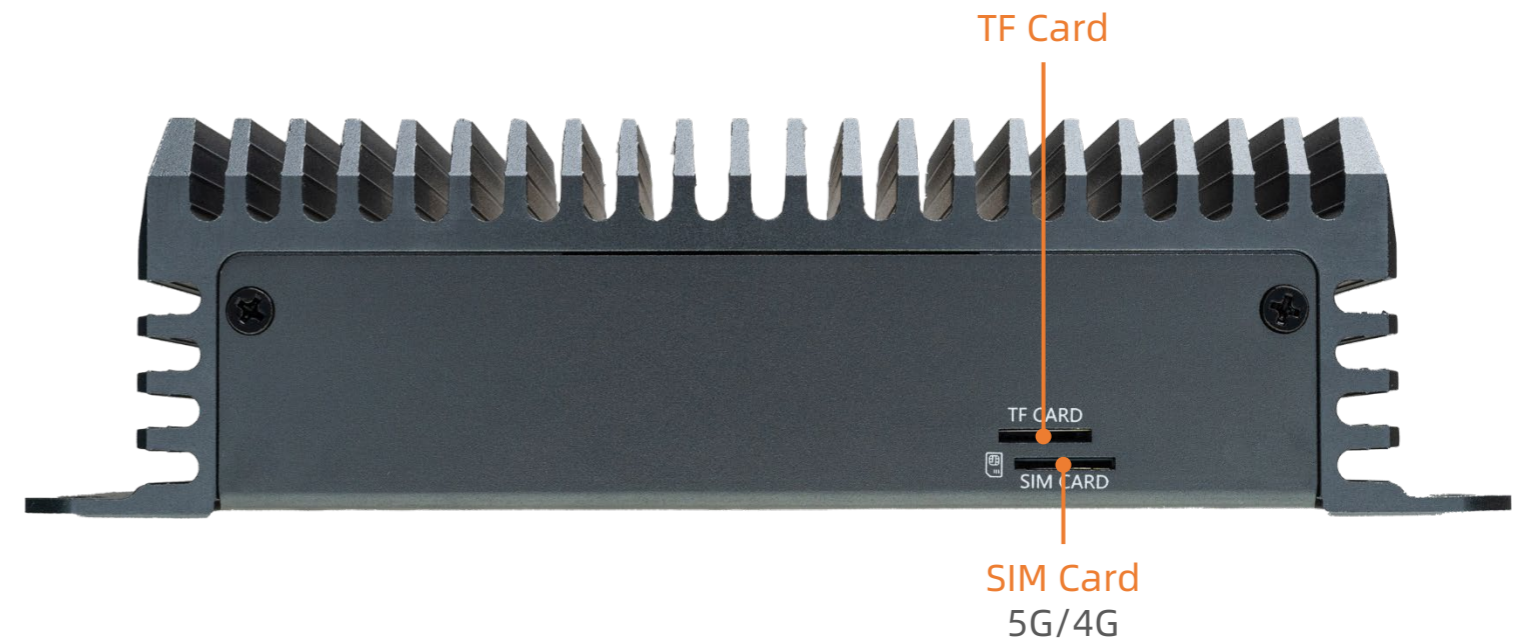

Dimension

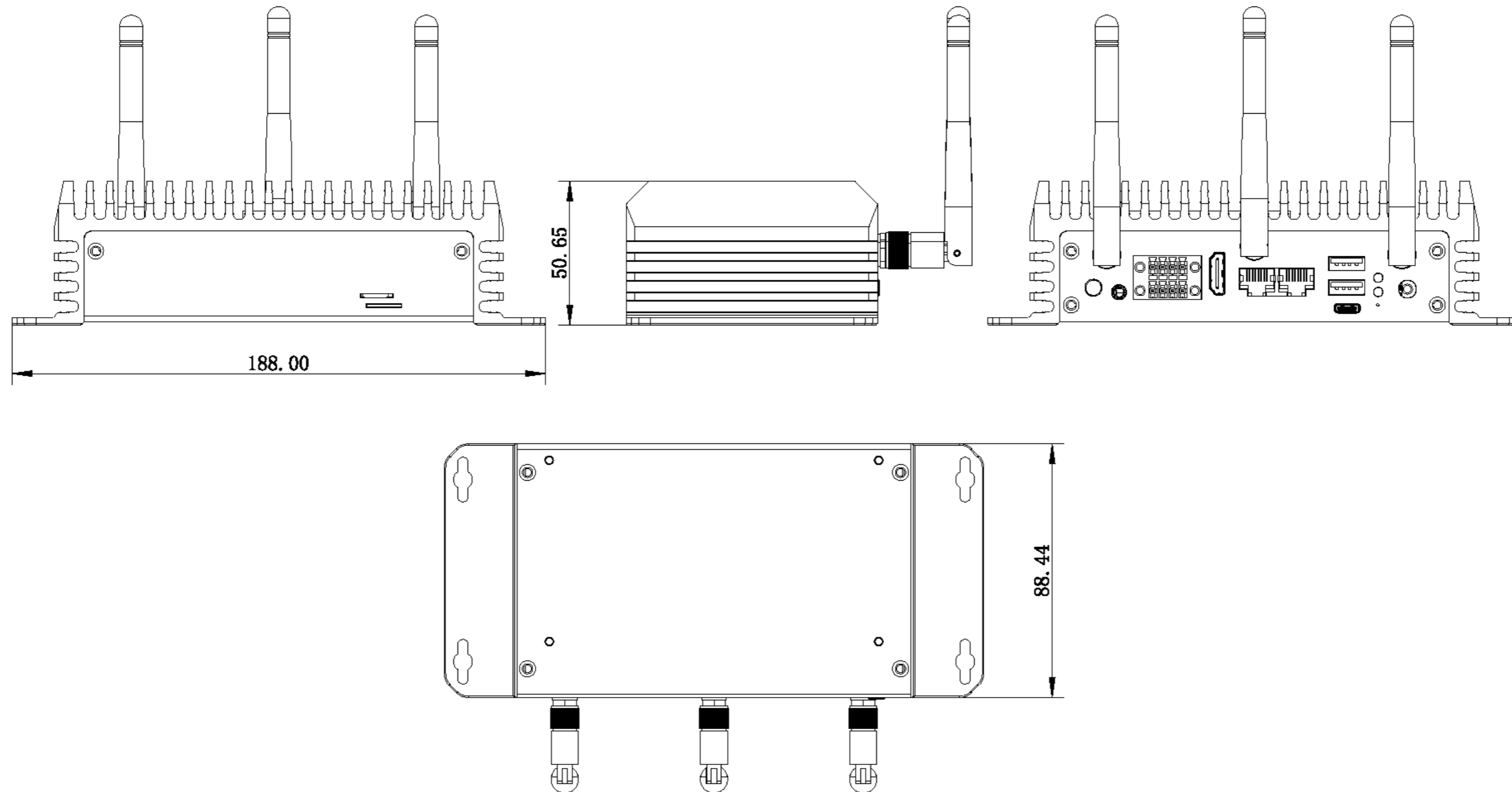



T-CHIP INTELLIGENCE TECHNOLOGY



Contact Us
(+86)18688117175



E-mail
global@t-firefly.com



Website
<https://en.t-firefly.com/>



Address
Room 2101, Hongyu Building, #57 Zhongshan 4Rd, East District,
Zhongshan, Guangdong, China.