

T-CHIP TECHNOLOGY

CAM-C1126S2U

Intelligent Dual-Lens Camera Module

V1.0



T-CHIP INTELLIGENCE TECHNOLOGY CO.,LTD.

www.t-firefly.com

Update history

Version	Date	Details
V1.0	2021-6-29	Original version

Directory

1. Overview.....	4
2. Technical Parameter.....	5
3. Size.....	6
4. Interface describe.....	7
5. Interface Definition	8
6. About us	12

1. Product Overview

Equipped with high-performance quad-core AI intelligent vision processor with computing power up to 2.0Tops, the module supports 4K video coding and decoding, various AI frameworks and human detection with high recognition accuracy — it is suitable for face recognition, gate access control, gesture recognition, expression recognition, face attribute analysis, etc. Abundant resources facilitate secondary development and help the project to be implemented quickly.



1. Quad-core AI vision processor

Low-consumption AI vision processor RV1126, with 14nm lithography process and quad-core 32-bit ARM Cortex-A7 architecture, integrates NEON and FPU — the frequency is up to 1.5GHz. It supports FastBoot, TrustZone technology and multiple crypto engines.

2. Various AI frameworks

Built-in neural network processor NPU with computing power up to 2.0 Tops realizes that the power consumption of AI computing is less than 10% of the power required by the GPU. With tools and supporting AI algorithms provided, it supports direct conversion and deployment of Tensorflow, PyTorch, Caffe, MxNet, DarkNet, ONNX, etc.

3. HDR+ WDR dual-lens

With built-in 3F-HDR ISP, multi-level noise reduction, 3F-HDR, and other technologies, it is equipped with dual-lens 2M (RGB+IR) WDR camera; it not only meets the scenes of strong light, backlight and darkness, but also realizes human detection and anti-spoofing functions of face recognition.

4. Efficient recognition, high accuracy

It supports face database up to 100,000 capacity; it has efficient recognition speed, and identifies the target quickly — the recognition accuracy rate is 99.7%.

5. 4K H.265 encoding & decoding

Built-in Video CODEC supports 4K H.264/H.265@30FPS and multi-channel video encoding and decoding, meeting the needs of low bit rate, low-latency encoding, perceptual encoding and making the video occupancy smaller.

6. Master & slave integration

It can be used as a USB device to output visual processing data and images to the computer; or can be used as an IPCAM monitoring and identification front end to connect to the NVR through the network port; and also can be connected to a 1080P screen through MIPI to make a face recognition or an AI vision terminal.

7. Small size, easy to integrate

Equipped with all-aluminum alloy shell, the space-saving module has efficient heat dissipation and can be flexibly embedded in various AI products.

8. Abundant resources for customization

A complete SDK, including cross compiler toolchain, BSP source code, application development environment, development documents, examples and other resources, is provided for the users to make a further customization.

9. Applications

It is widely used in face recognition, gesture recognition, gate access control, smart security, smart IP camera, smart doorbell/peephole, self-service terminals, smart finance, smart construction, smart travel and other industries.

2. Specifications

Main Specifications		
SoC	RV1126	
CPU	Quad-core ARM Cortex-A7 32-bit, frequency 1.5GHz, integrate NEON and FPU, Each core has a 32KB I-cache, 32KB D-cache and 512KB shared second-level cache Based on RISC-V MCU	
NPU	Computing power up to 2.0Tops, supports INT8/ INT16, It has strong network model compatibility and provides RKNN tool, which can realize the conversion of commonly used AI framework models Eg: (caffe, darknet, mxnet, onnx, pytorch, tensorflow, tflite) and algorithm support	
RAM	1GB / 2GB DDR4	
Storage	8GB / 16GB eMMC	
Video Encoding	4K H.264/H.265 30fps video encoding: 3840 x 2160@30 fps+720p@30 fps encoding	
Video Decoding	4K H.264/H.265 30fps video decoding 3840 x 2160@30 + 3840 x 2160@30 fps decoding	
OS	Linux	
Power	5V	
Temperature	Operating Temperature : -20°C ~ 60°C	
Humidity	Storage Humidity : 10% ~ 90%RH(non-condensing)	
Dual-Lens Camera		
	Camera (IR)	Camera (RGB)
Image Sensor	GC2053	GC2093
Sensor Size	1 / 2.9	1 / 2.9
Resolution	1920*1080	1920*1080
Pixel Size	2.8 μm	2.8 μm
Output Format	RAW	RAW
Interface	MIPI	MIPI
Focus Distance	80 cm	80 cm
Lens	4P	4P
Filter	850 nm	650 nm
Field Angle	D70°H62°V38°	D70°H62°V38°
Distortion	≤0.5%	≤0.5%
Aperture/ Focal Length	F2.0/4.3mm	F2.0/4.3mm
Resolving Power	Center: 800 Around: 600	Center: 800 Around: 600
Face Recognition & Detection		
Max Database	100,000	
Recommended Database	10,000	
Accuracy	Under standard test environment, 10,000 database No Mask: Accuracy 99% With mask: Accuracy 95%	
Face Detection	Face detection time: ~23ms Face tracking time: ~7ms	
Human Detection	Single-lens detection time: ~45ms Dual-lens detection time: ~15ms	
Face Recognition	Feature extraction time: ~25ms Single recognition time: ~0.0115ms	
Recommended Image Input Size	720P	
Min Face Recognition Size	50*50 pixel (Non-human) 90*90 pixel (Human)	
Recommended Face Recognition Angle	Yaw ≤ ±30° Pitch ≤ ±30° Roll ≤ ±30°	
Appearance		
Dimension	84.0mm × 22.45mm × 19.35mm	
Shell	All aluminum alloy design, efficient heat dissipation	
Power consumption	Normal: 2.8W (5V/560mA) Min: 0.71W (5V/142mA) Max: 4.3W (5V/860mA) Recommended power supply: 5V/1.2A or above	

3. Size

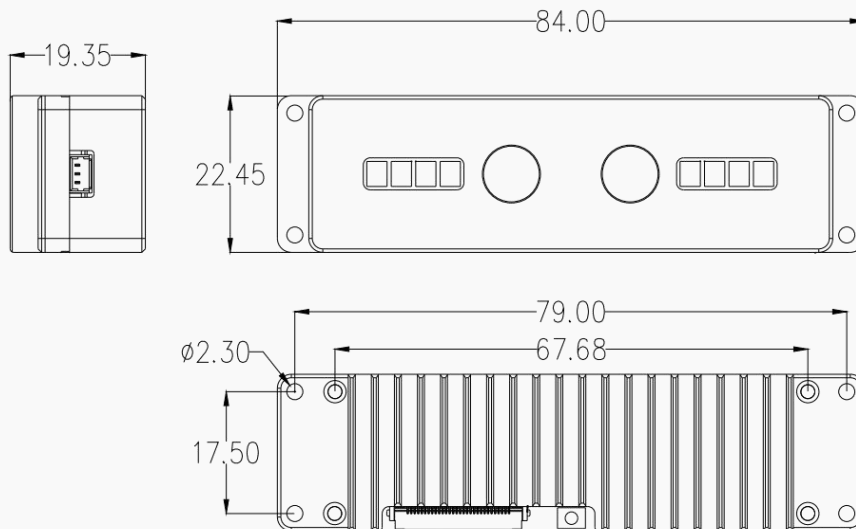

4. Interface

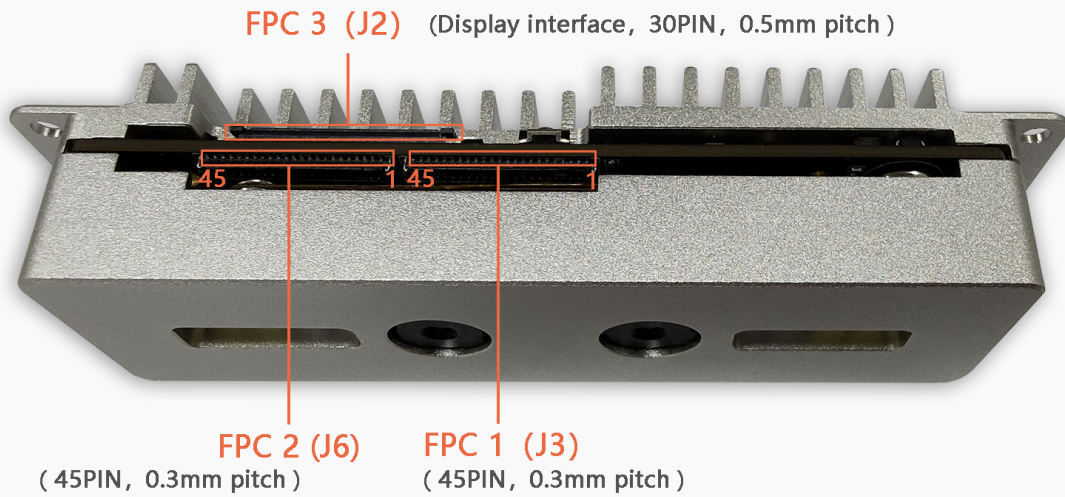

5. Interface Definition

1、FPC 1 (J3)

PIN	Core board pin definition	Default function	Defual function description	IO Power domain	Pad type IO Pull
1	USB_HOST_DM	HOSTDM	USB HOST Data Minus port		
2	USB_HOST_DP	HOSTDP	USB HOST Data Plus port		
3	5V	5V supply	Output Voltage 4.8V-5.5V current Max 100mA		
4	5V	5V supply	Output Voltage 4.8V-5.5V current Max 100mA		
5	GND	GND	Power ground		
6	SPI0_MOSI_M0/GPIO0_A6_d	WIFI_REG_ON	Power up/down internal regulators used by WiFi section	1.8V	DOWN
7	SPI0_CLK_M0/GPIO0_B0_d	WIFI_WAKE_HOST	WIFI module wake up AP	1.8V	DOWN
8	SPI0_CS1n_M0/GPIO0_A4_u	BT_WAKE	HOST wake-up Bluetooth device	1.8V	UP
9	SPI0_MISO_M0/GPIO0_A7_d	BT_RST	BT RESET	1.8V	DOWN
10	UART0_TX /GPIO1_C3_U	UART0_TX	UART0 TX data	1.8V	UP
11	CLK32K	CLK32K	32KHZ CLOCK		
12	UART0_RTSN /GPIO1_C0_U	UART0_RTSN	UART0 request-to-send signal	1.8V	UP
13	UART0_RX /GPIO1_C2_U	UART0_RX	UART0 RX data	1.8V	UP
14	SPI0_CS0n_M0/GPIO0_A5_u	BT_WAKE_HOST	Bluetooth device to wake –up host	1.8V	UP
15	UART0_CTSN/ GPIO1_C1_U	UART0_CTSN	UART0 clear-to-send signal	1.8V	UP
16	LCDC_D1/RGMII_CRS_M1/CIF_D1_M1/UART4_CTSN_M1/I2C5_SCL_M0/GPIO2_A5_d	EPHY_RSTN	PHY_RSTN	3.3V	DOWN
17	SDMMC1_CLK/ GPIO1_B2_D	SDIO_CLK	SDIO clock, for WIFI module	1.8V	DOWN
18	SDMMC1_D2 GPIO1_B6_U	SDIO_D2	SDIO data2, for WIFI module	1.8V	UP
19	GND	GND	POWER GROUND		
20	SDMMC1_D0 GPIO1_B4_U	SDIO_D0	SDIO data0, for WIFI module	1.8V	UP
21	SDMMC1_CMD GPIO1_B3_U	SDIO_CMD	SDIO command, for WIFI module	1.8V	UP
22	SDMMC1_D3 GPIO1_B7_U	SDIO_D3	SDIO data3, for WIFI module	1.8V	UP
23	SDMMC1_D1 GPIO1_B5_U	SDIO_D1	SDIO data1, for WIFI module	1.8V	UP
24	LCDC_D19/RGMII_RXD2_M1/CIF_D15_M1/I2S1_MCLK_M2/GPIO2_C7_d	GMAC_RXD2	MAC RX data2	3.3V	DOWN
25	ADCIN1	ADC_IN			
26	I2S1_SDO_M2/RGMII_RXD3_M1 /CIF_VSYNC_M1/LCDC_D20 /GPIO2_D0_D	GMAC_RXD3	MAC RX data3	3.3V	DOWN
27	I2S1_SDI_M2/RGMII_RXCLK_M1/ CIF_HSYNC_M1/LCDC_D23/GPIO2_D3_D	GMAC_RXCLK	MAC RX clock	3.3V	DOWN
28	RGMII_RXDV_M1/CIF_D4_M1 /LCDC_D8 /GPIO2_B4_D	GMAC_RXDV	RX data validity and carrier sense signal of the RMII	3.3V	DOWN
29	RGMII_RXD0_M1/CIF_D5_M1 /LCDC_D9 /GPIO2_B5_D	GMAC_RXD0	MAC RX data0	3.3V	DOWN
30	RGMII_RXD1_M1/CIF_D6_M1/ LCDC_D10 /GPIO2_B6_D	GMAC_RXD1	MAC RX data1	3.3V	DOWN
31	RGMII_TXEN_M1/CIF_D14_M1/ LCDC_D18 /GPIO2_C6_D	GMAC_TXEN	MAC TX data validity signal	3.3V	DOWN
32	RGMII_TXD1_M1/CIF_D12_M1 LCDC_D16 /GPIO2_C4_D	GMAC_TXD1	MAC TX data1	3.3V	DOWN
33	I2S1_LRCK_M2/RGMII_TXCLK_M1 /CIF_CLKIN_M1/LCDC_D22 /GPIO2_D2_D	GMAC_TXCLK	The transmit reference clock / FOCUS_EN	3.3V	DOWN
34	GND	GND	POWER GROUND		
35	LCDC_D15/RGMII_TXD0_M1/CIF_D11_M1/GPIO2_C3_d	GMAC_TXD0	MAC TX data0	3.3V	DOWN

36	UART4_RTSN_M1/RGMII_TXD3_M1/CIF_D0_M1/LCDC_D0/GPIO2_A4_D	GMAC_TXD3	MAC TX data3	3.3V	DOWN
37	I2S1_SCLK_M2/RGMII_TXD2_M1/CIF_CLKOUT_M1/LCDC_D21/GPIO2_D1_D	GMAC_TXD2	RGMII TX data2	3.3V	DOWN
38	LCDC_D17/CLK_OUT_ETHERNET_M1/CIF_D13_M1/GPIO2_C5_d	CLK_25M_ETHERNET	Output reference Clock to PHY	3.3V	DOWN
39	LCDC_D11/RGMII_CLK_M1/CIF_D7_M1/GPIO2_B7_d	GMAC_CLK	MAC REC_CLK output or external clock input	3.3V	DOWN
40	RGMII_MDIO_M1/CIF_D9_M1/LCDC_D13/GPIO2_C1_D	GMAC_MDIO	MDIO interface data	3.3V	DOWN
41	RGMII_MDC_M1/CIF_D10_M1/LCDC_D14/GPIO2_C2_D	GMAC_MDC	MDIO interface Clock	3.3V	DOWN
42	CAN_TXD_M0/UART3_RX_M2/PWM11_IR_M1/I2C4_SDA_M0/GPIO3_A1_u	UART3_RX	UART3 RX data	3.3V	UP
43	LCDC_D2/RGMII_COL_M1/CIF_D2_M1/PWM5_M1/UART4_TX_M1/GPIO2_A6_d	EPHY_PMEB	EPHY_PMEB	3.3V	DOWN
44	CAN_RXD_M0/UART3_TX_M2/PWM7_IR_M1/SPI1_CS1n_M2/I2C4_SCL_M0/GPIO3_A0_u	UART3_TX	UART3 Tx data	3.3V	UP
45	GND	GND	POWER GROUND		

2、FPC 2 (J6)

PIN	Core board pin definition	Default function	Default function description	IO Power domain	Pad type IO Pull
1	SDMMC0_DET/ GPIO0_A3_U	SDMMC0_DET		1.8V	UP
2	I2S0_MCLK_M0/GPIO3_D2_d	I2S0_MCLK_M0	I2S/PCM clock to external device	3.3V	DOWN
3	I2S0_SCLK_TX_M0/ACODEC_DAC_CLK/GPIO3_D0_d	I2S0_SCLK_TX_M0	I2S/PCM serial clock	3.3V	DOWN
4	I2S0_SDO3_SDI1_M0/PDM_SDI1_M0/AUDPWM_R_M0/I2C4_SDA_M1/AUDDSM_RP/GPIO4_A1_d	I2C4_SDA	Data/Address of I2C bus4	3.3V	
5	I2S0_SDI0_M0/PDM_SDI0_M0/ACODEC_DAC_DATA/GPIO3_D6_d	I2S0_SDI0_M0	serial data0 input of I2S0 or PCM interface	3.3V	DOWN
6	I2S0_SDO2_SDI2_M0/PDM_SDI2_M0/AUDPWM_L_M0/I2C4_SCL_M1/AUDDSM_RN/GPIO4_A0_d	I2C4_SCL	Clock of I2C bus4	3.3V	DOWN
7	I2S0_SDO0_M0/ACODEC_DAC_DATA/AUDPWM_R_M1/AUDDSM_LP/GPIO3_D5_d	I2S0_SDO0_M0	serial data0 output of I2S0 or PCM interface	3.3V	DOWN
8	I2S0_LRCK_TX_M0/ACODEC_DAC_SYNC/AUDPWM_L_M1/AUDDSM_LN/GPIO3_D3_d	I2S0_LRCK_TX_M0	I2S/PCM left & right channel signal for receiving serial data, synchronous left & right channel in I2S mode and the beginning of a group of left & right channels in PCM mode	3.3V	DOWN
9	LCDC_D3/I2S2_SDO_M1/UART4_RX_M1/PWM4_M1/SPI0_CS0n_M2/GPIO2_A7_d	SPI0_CS0N_M2	CS signal0 of SPI0	3.3V	DOWN
10	LCDC_D5/I2S2_SCLK_M1/UART5_RX_M1/PWM2_M1/SPI0_MISO_M2/GPIO2_B1_d	SPI0_MISO_M2	Data input of SPI0	3.3V	DOWN
11	LCDC_D4/I2S2_SDI_M1/UART5_TX_M1/PWM3_IR_M1/SPI0_MOSI_M2/GPIO2_B0_d	SPI0_MOSI_M2	Data output of SPI0	3.3V	DOWN
12	LCDC_D6/I2S2_LRCK_M1/UART5_RTSN_M1/PWM1_M1/SPI0_CLK_M2/GPIO2_B2_d	SPI0_CLK_M2	Clock signal of SPI0	3.3V	DOWN
13	SDMMC0_D3/UART3_TX_M1/A7_JTAG_TMS_M0/MCU_JTAG_TMS/GPIO1_A7_u	SDMMC0_D3	SDMMC0 data3	3.3V	UP
14	SDMMC0_D2/UART3_RX_M1/A7_JTAG_TCK_M0/MCU_JTAG_TCK/GPIO1_A6_u	SDMMC0_D2	SDMMC0 data2	3.3V	UP
15	GND	GND	POWER GROUND		
16	SDMMC0_CLK/UART3_RTSN_M1/MCU_JTAG_TDO/GPIO1_B0_u	SDMMC0_CLK	SDMMC0 clock	3.3V	UP
17	SDMMC0_D1/TEST_CLK0_OUT/UART2_TX_M0/MCU_JTAG_TRSTn/GPIO1_A5_u	SDMMC0_D1	SDMMC0 data1	3.3V	UP

18	SDMMC0_CMD/UART3_CTSN_M1/MCU_JTAG_TDI/GPIO1_B1_u	SDMMC0_CMD	SDMMC0 command	3.3V	UP
19	SDMMC0_D0/TEST_CLK1_OUT/UART2_RX_M0/GPIO1_A4_u	SDMMC0_D0	SDMMC0 data0	3.3V	UP
20	GND	GND	POWER GROUND		
21	LCDC_D7/I2S2_MCLK_M1/CIF_D3_M1/UART5_CTSN_M1/SPI0_CS1n_M2/PWM0_M1/I2C5_SDA_M0/GPIO2_B3_d	GPIO2_B3_D	GPIO	3.3V	DOWN
22	CIF_D14_M0/RGMII_RXER_M0/PDM_SDI1_M1/GPIO3_C2_d	CIF_D14	CIF data 14	3.3V	DOWN
23	CIF_D15_M0/RGMII_MDIO_M0/PDM_CLK1_M1/GPIO3_C3_d	CIF_D15	CIF data 15	3.3V	DOWN
24	CIF_D13_M0/RGMII_RXDV_M0/PDM_SDI0_M1/GPIO3_C1_D	CIF_D13	CIF data 13	3.3V	DOWN
25	CIF_CLKIN_M0/CLK_OUT_ETHERNET_M0/UART3_CTSN_M0/GPIO3_C5_d	CIF_CLKIN	CIF clock INPUT	3.3V	DOWN
26	CIF_D12_M0/RGMII_CLK_M0/PDM_CLK0_M1/SPI1_CLK_M0/GPIO3_C0_d	CIF_D12	CIF data 12	3.3V	DOWN
27	CIF_VSYNC_M0/RGMII_MDC_M0/UART3_RTSN_M0/GPIO3_C4_d	CIF_VSYNC	CIF field sync signal	3.3V	DOWN
28	CIF_HSYNC_M0/RGMII_RXCLK_M0/UART3_RX_M0/GPIO3_C7_d	CIF_HSYNC	CIF horizontal sync signal	3.3V	DOWN
29	CIF_D9_M0/RGMII_TXEN_M0/I2S0_SDO3_SDI1_M1/SPI1_CS0n_M0/GPIO3_B5_d	CIF_D9	CIF data 9	3.3V	DOWN
30	CIF_CLKOUT_M0/RGMII_TXCLK_M0/UART3_TX_M0/GPIO3_C6_d	CIF_CLKOUT	CIF clock output	3.3V	DOWN
31	CIF_D10_M0/RGMII_RXD0_M0/PDM_SDI2_M1/SPI1_MOSI_M0/GPIO3_B6_d	CIF_D10	CIF data 10	3.3V	DOWN
32	CIF_D7_M0/RGMII_TXD0_M0/I2S0_SDO1_SDI3_M1/UART4_CTSN_M0/GPIO3_B3_d	CIF_D7	CIF data 7	3.3V	DOWN
33	CIF_D11_M0/RGMII_RXD1_M0/PDM_SDI3_M1/SPI1_MISO_M0/GPIO3_B7_d	CIF_D11	CIF data 11	3.3V	DOWN
34	CIF_D6_M0/RGMII_TXD3_M0/I2S0_LRCK_RX_M1/UART4_RTSN_M0/GPIO3_B2_d	CIF_D6	CIF data 6	3.3V	DOWN
35	CIF_D2_M0/RGMII_COL_M0/I2S0_SDO0_M1/UART5_TX_M0/CAN_RXD_M1/PWM10_M0/GPIO3_A6_d	CIF_D2	CIF data 2	3.3V	DOWN
36	CIF_D3_M0/RGMII_RXD2_M0/I2S0_SDI0_M1/UART5_RX_M0/CAN_TXD_M1/PWM11_IR_M0/GPIO3_A7_d	CIF_D3	CIF data 3	3.3V	DOWN
37	CIF_D8_M0/RGMII_TXD1_M0/I2S0_SDO2_SDI2_M1/SPI1_CS1n_M0/GPIO3_B4_d	CIF_D8	CIF data 8	3.3V	DOWN
38	CIF_D0_M0/I2S0_SCLK_TX_M1/UART4_TX_M0/I2C3_SCL_M0/PWM8_M0/GPIO3_A4_d	CIF_D0	CIF data 0	3.3V	DOWN
39	CIF_D1_M0/RGMII_CRS_M0/I2S0_LRCK_TX_M1/UART4_RX_M0/I2C3_SDA_M0/PWM9_M0/GPIO3_A5_d	CIF_D1	CIF data 1	3.3V	DOWN
40	GND	GND	POWER GROUND		
41	CIF_D5_M0/RGMII_TXD2_M0/I2S0_SCLK_RX_M1/UART5_CTSN_M0/I2C5_SDA_M1/GPIO3_B1_d	CIF_D5	CIF data 5	3.3V	DOWN
42	CIF_D4_M0/RGMII_RXD3_M0/I2S0_MCLK_M1/UART5_RTSN_M0/I2C5_SCL_M1/GPIO3_B0_d	CIF_D4	CIF data 4	3.3V	DOWN
43	GND	GND	POWER GROUND		
44	5V	5V	Output Voltage 4.8V-5.5V current Max 100mA		
45	5V	5V	Output Voltage 4.8V-5.5V current Max 100mA		

3、FPC 3 (J2)

PIN	RK1126 pin definition	Default function	Defual function description	IO Power domain	Pad type IO Pull
1	VCC_5V	5.0V Out	Output Voltage 4.8V-5.0V current Max 300mA	5.0V	
2	VCC_5V			5.0V	
3	VCC_5V			5.0V	
4	GND	GND	POWER GROUND		
5	NC	NC			
6	VCC_3.3V	3.3V Out	Output Voltage 3.3V current Max 500mA	3.3V	
7	LCDC_HSYNC/PWM10_M1/SPI1_CLK_M2/I2C3_SDA_M1/GPIO2_D5_d	I2C3_SDA	I2C_ SDA	3.3V	DOWN
8	LCDC_DEN/PWM6_M1/SPI1_CS0n_M2/I2C3_SCL_M1/GPIO2_D4_d	I2C3_SCL	I2C_ SCL	3.3V	DOWN
9	I2C2_SDA/PWM5_M0/GPIO0_C3_d	LCD_EN	LCD_EN, Active H	3.3V	DOWN
10	LCDC_VSYNC/UART3_RTSN_M2/PWM9_M1/SPI1_MOSI_M2/GPIO2_D6_d	TP_INT	TP_INT , Active L	3.3V	DOWN
11	LCDC_D12/RGMII_RXER_M1/CIF_D8_M1/GPIO2_C0_d	BL_EN	BL_EN, Active H	3.3V	DOWN
12	PMIC_SLEEP/TSADC_SHUT_M1/PWM6_M0/GPIO0_B2_d	LCD_BL_PWM	BL_PWM	3.3V	DOWN
13	LCDC_CLK/UART3_CTSN_M2/PWM8_M1/SPI1_MISO_M2/GPIO2_D7_d	LCD_RST	LCD_RST, Active L	3.3V	DOWN
14	I2C2_SCL/PWM4_M0/GPIO0_C2_d	TP_RST	TP_RST, Active L	3.3V	DOWN
15	GND	GND	POWER GROUND		
16	MIPI_DSI_D0P	MIPI_D0+	MIPI_D0+ OUT	1.8V	
17	MIPI_DSI_D0N	MIPI_D0-	MIPI_D0- OUT	1.8V	
18	GND	GND	POWER GROUND		
19	MIPI_DSI_D1P	MIPI_D1+	MIPI_D1+ OUT	1.8V	
20	MIPI_DSI_D1N	MIPI_D1-	MIPI_D1- OUT	1.8V	
21	GND	GND	POWER GROUND		
22	MIPI_DSI_CLKP	MIPI_CLK+	MIPI_CLK+ OUT	1.8V	
23	MIPI_DSI_CLKN	MIPI_CLK-	MIPI_CLK- OUT	1.8V	
24	GND	GND	POWER GROUND		
25	MIPI_DSI_D2P	MIPI_D2+	MIPI_D2+ OUT	1.8V	
26	MIPI_DSI_D2N	MIPI_D2-	MIPI_D2- OUT	1.8V	
27	GND	GND	POWER GROUND		
28	MIPI_DSI_D3P	MIPI_D3+	MIPI_D3+ OUT	1.8V	
29	MIPI_DSI_D3N	MIPI_D3-	MIPI_D3- OUT	1.8V	
30	GND	GND	POWER GROUND		

J4700 (MIPI CSI Interface)

PIN	RK1126 pin definition	Default function	Default function description	IO Power domain	Pad type IO Pull
1	AVDD_2V8	2.8V OUTPUT, Max 500mA	IR_AVDD	2.8V	
2	VCC3V3_SYS	3.3V OUTPUT, Max 500mA	RGB_AVDD	3.3V	
3	GND	GND	Power ground		
4	IR_PWDN	IR- PWER EN	For IR Camera	3.3V	
5	IR_RESET	IR_RESET,Active L	For IR Camera	3.3V	
6	I2C1_SCL	I2C1_SCL(pullup resistor 2.2K)	IR+RGB	1.8V	UP
7	I2C1_SDA	I2C1_SDA(pullup resistor 2.2K)	IR+RGB	1.8V	UP
8	GND	GND	Power ground		
9	MIPI_CSI_CLK0	MIPI_CSI_CLK0 OUTPUT	For IR Camera	1.8V	DOWN
10	GND	GND	Power ground		
11	MIPI_CSI_RX0_CLKP	MIPI_CSI_RX0_CLK+	For IR Camera	1.8V	
12	MIPI_CSI_RX0_CLKN	MIPI_CSI_RX0_CLK-	For IR Camera	1.8V	
13	GND	GND	Power ground		
14	MIPI_CSI_RX0_D0P	MIPI_CSI_RX0_D0+	For IR Camera	1.8V	
15	MIPI_CSI_RX0_D0N	MIPI_CSI_RX0_D0-	For IR Camera	1.8V	
16	GND	GND	Power ground		
17	MIPI_CSI_RX0_D1P	MIPI_CSI_RX0_D1+	For IR Camera	1.8V	
18	MIPI_CSI_RX0_D1N	MIPI_CSI_RX0_D1-	For IR Camera	1.8V	
19	GND	GND	POWER GROUND		
20	MIPI_CSI_RX0_D2P	MIPI_CSI_RX0_D2+	For IR Camera	1.8V	
21	MIPI_CSI_RX0_D2N	MIPI_CSI_RX0_D2-	For IR Camera	1.8V	
22	GND	GND	Power ground		
23	NC	NC			
24	VCC_1V8	1.8V OUT ,MAX 200mA	IR+RGB	3.3V	
25	FSVNC	Default NC	IR+RGB		
26	DVDD_1V2	1.2V OUT ,MAX 300mA	For IR Camera	1.2V	
27	DVDD_1V3	1.3V OUT ,MAX 300mA	For RGB Camera	1.3V	
28	GND	GND	Power ground		
29	MIPI_RX0_PDN	MIPI_ PDN	For RGB Camera	1.8V	DOWN
30	MIPI_RX0_RST	MIPI _RST, Active L	For RGB Camera	1.8V	DOWN
31	GND	GND	Power ground		
32	MIPI_CSI_CLK1	MIPI_CSI_CLK1 Output	For RGB Camera	1.8V	DOWN
33	GND	GND	Power ground		
34	MIPI_CSI_RX1_CLKP	MIPI_CSI_RX1_CLK+	For RGB Camera	1.8V	
35	MIPI_CSI_RX1_CLKN	MIPI_CSI_RX1_CLK-	For RGB Camera	1.8V	
36	GND	GND	Power ground		
37	MIPI_CSI_RX1_D0P	MIPI_CSI_RX1_D0+	For RGB Camera	1.8V	
38	MIPI_CSI_RX1_D0N	MIPI_CSI_RX1_D0-	For RGB Camera	1.8V	
39	GND	GND	Power ground		
40	MIPI_CSI_RX1_D1P	MIPI_CSI_RX1_D1+	For RGB Camera	1.8V	
41	MIPI_CSI_RX1_D1N	MIPI_CSI_RX1_D1-	For RGB Camera	1.8V	
42	GND	GND	Power ground		
43	MIPI_CSI_RX1_D2P	MIPI_CSI_RX1_D2P	For RGB Camera	1.8V	
44	MIPI_CSI_RX1_D2N	MIPI_CSI_RX1_D2N	For RGB Camera	1.8V	
45	GND	GND	POWER GROUND		

Company profile

T-Chip Intelligent Technology (Zhongshan) Co., Ltd. , established in 2005, has more than ten years of technological product research and development capabilities, and has nearly 100 patents and software copyrights. As a national high-tech enterprise, we focus on the research and development, production and sales of open source smart hardware, Internet of Things, and digital audio products, while also provide overall solutions with smart hardware products.

T-Chip is an IDH (Independent Design House) officially authorized by Rockchip in Fuzhou, and also a strategic partner of Rockchip, with a close cooperative relationship for more than 10 years. Firefly is a brand established by T-Chip, with open source community and online store. Firefly products include core boards, mainboards, embedded computers, cluster servers, development kits and other products. Currently, we have more than 100,000 users, including more than 10,000 enterprise users such as Arm, Google, Baidu, Tencent and Alibaba.

Firefly team has more than 70 R&D members, with excellent research and development capabilities of schematic design, PCB layout, board mass production, embedded development, system development, application development and so on. We accelerate the research and development process for many technology entrepreneurs and start-ups, and provide professional technical services.

Make technology simpler, Make life smarter - is the idea of Firefly team. We hope that through Firefly's open source products and technical services, the research and development of various technological products will become efficient and simple, and intelligent technology can be integrated into life.

Firefly is committed to providing enterprise customers with long-term stable and reliable industrial products and services, and continuously creating value for customers.

T-Chip Intelligent Technology Co., Ltd.

Website: www.t-firefly.com

Tel: 4001-511-533

P.C.: 528400

Addr: Room 2101, Hongyu Building, #57 Zhongshan 4Rd, East District, Zhongshan, Guangdong, China.

Business Communication

E-mail: sales@t-firefly.com

Shopping Mall

- 1) store.t-firefly.com
- 2) t-firefly.taobao.com



Contact us