

CONTENT INDEXING

- 01. INDEX
- 02. Change List
- 03. Block Diagram
- 04.DC_IN/IR
- 05.USB Port
- 06.TF card/RTC
- 07.10/100/1000M-PHY
- 08.AUDIO/CVBS
- 09.WIFI/BT-AP6XXX
- 10.HDMI OUT
- 11.SPDIFF/KEY
- 12.Connector1
- 13.Connector2

PCB POWER WIRE WIDTH INDICATE

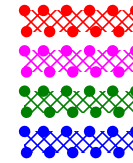

No indicate

above 80 miles

above 50 miles

above 30 miles

above 16 miles

Under needs

4 LAYERS PCB STACK

TOP	 Prepreg 3313*1 4.0MIL(0.10mm)	Hoz(18um) + plating copper(18um)
GND	 Adjust	1oz(35um)
POWER	 Prepreg 3313*1 4.0MIL(0.10mm)	1oz(35um)
BOTTOM	 Prepreg 3313*1 4.0MIL(0.10mm)	Hoz(18um) + plating copper(18um)



www.t-firefly.com

Title: Index

File: FirePrime

REV: 12

Create Date: Monday, June 01, 2015

Page Num: 1

Modify Date: Friday, May 13, 2016

Page Total: 13

Version	Date	Author	Change Note	Note
V00	20150130	HWQ	The first edit.	
V01	20150312	HWQ	Increase pull-up resistor for SDIO1.	
V10	20150611	HWQ	1. HDMI's power was changed. 2.GPIO2_A5 and GPIO0_D6 exchange.	
V11	20150725	HWQ	线路优化。	
V12	20160513	HWQ	1.增加加密IC. 2.PCB叠构更改。 3.陶瓷天线处优化。	

		www.t-firefly.com	
Title: Change List			
File: FirePrime			REV:12
Create Date: Monday, June 01, 2015		Page Num: 2	
Modify Date: Friday, May 13, 2016		Page Total: 13	

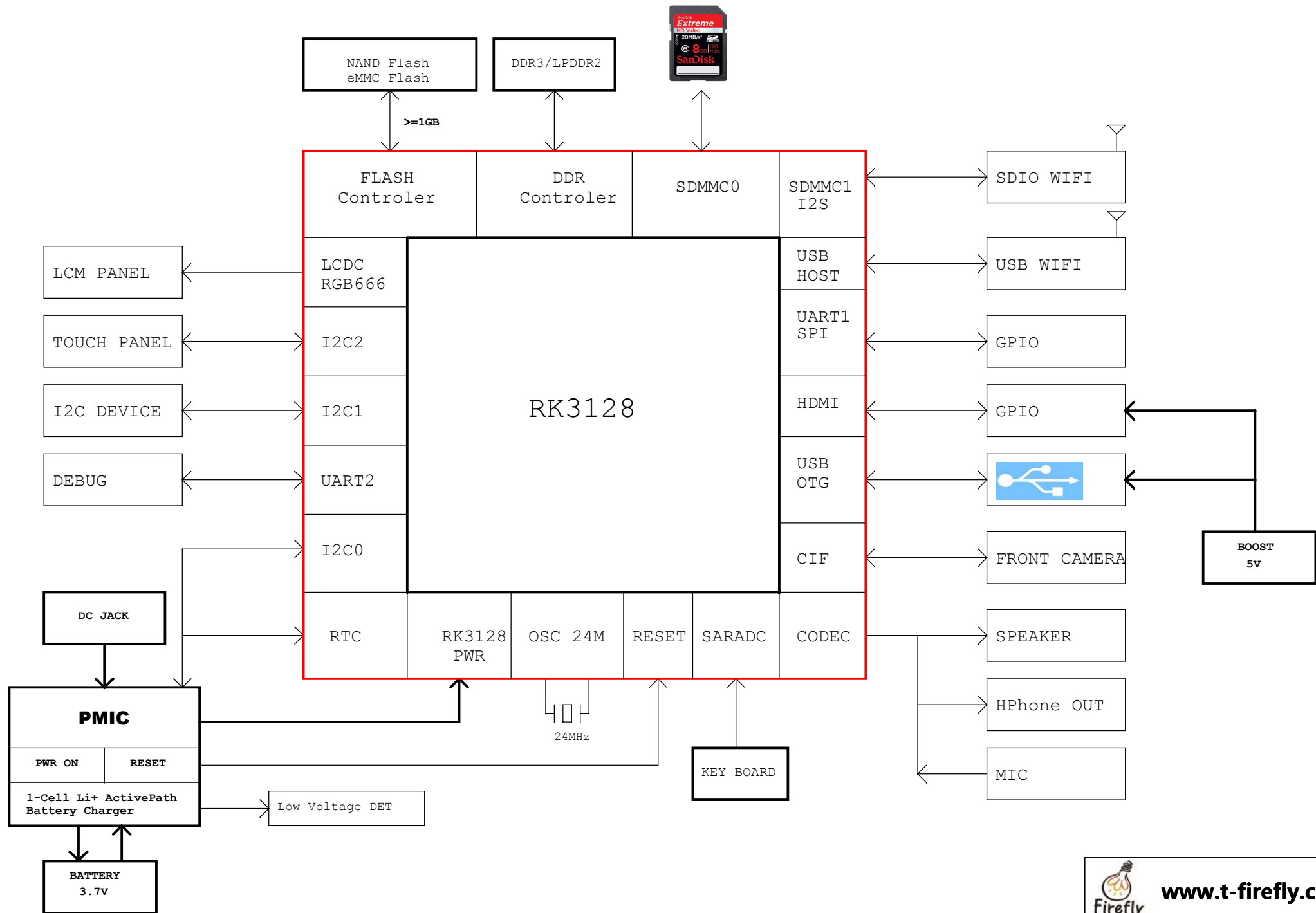

DC_IN

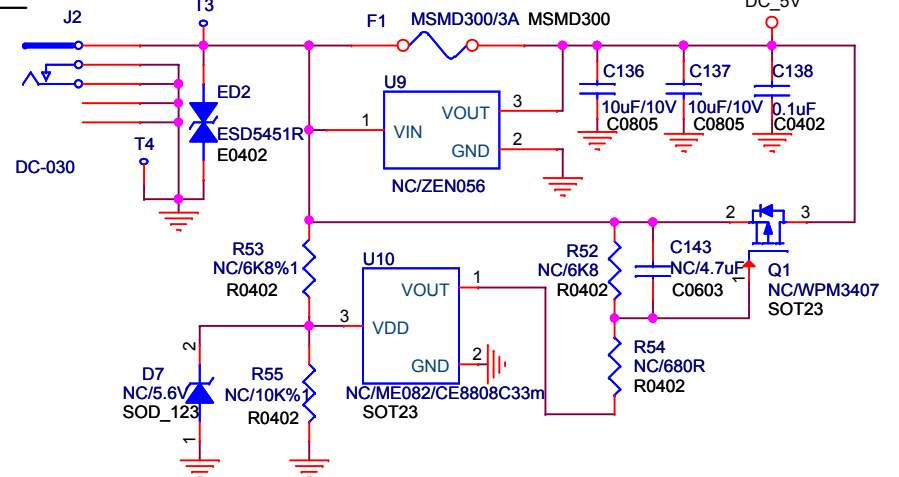

POWER_CTL

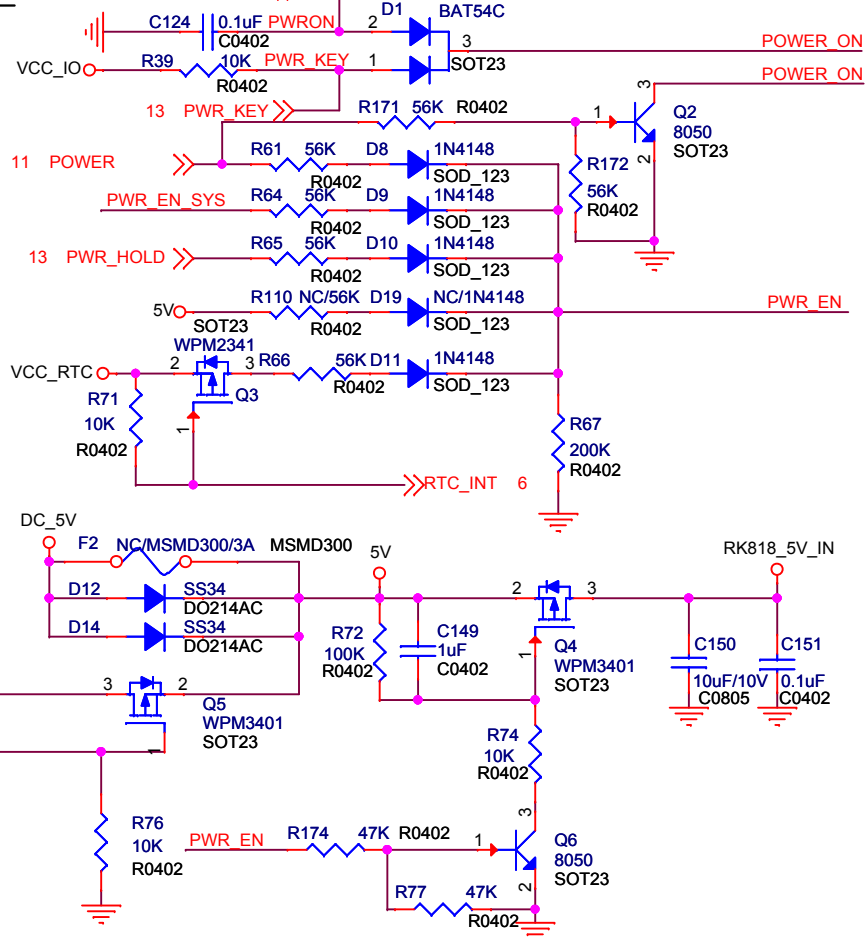

MCU

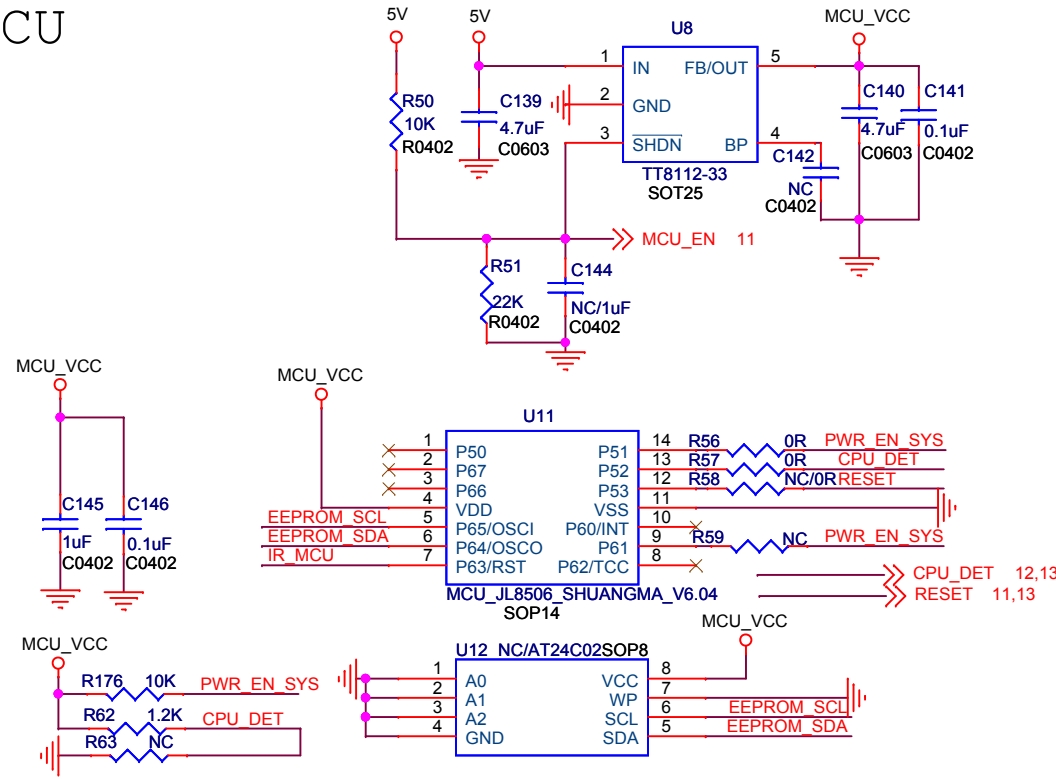

IR RECEIVE

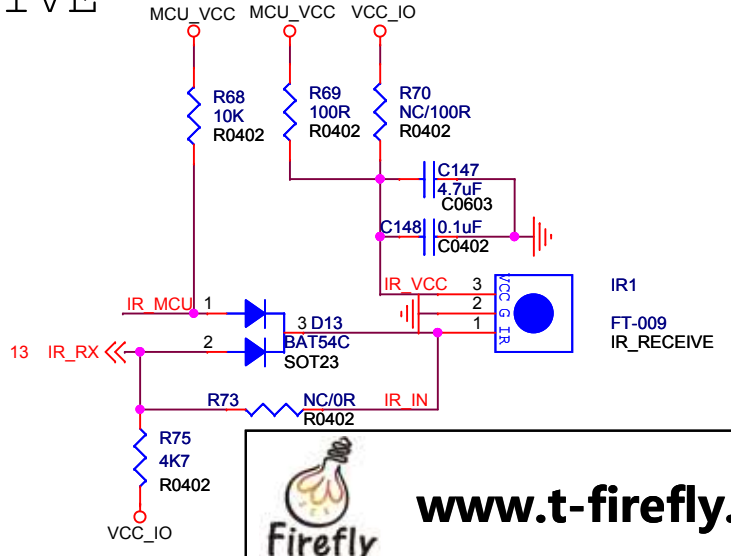

Title: DC IN/IR		REV: 12
File: FirePrime		
Create Date: Monday, June 01, 2015	Page Num: 4	
Modify Date: Friday, May 13, 2016	Page Total: 13	

BOOST/HOST, OTG_POWER

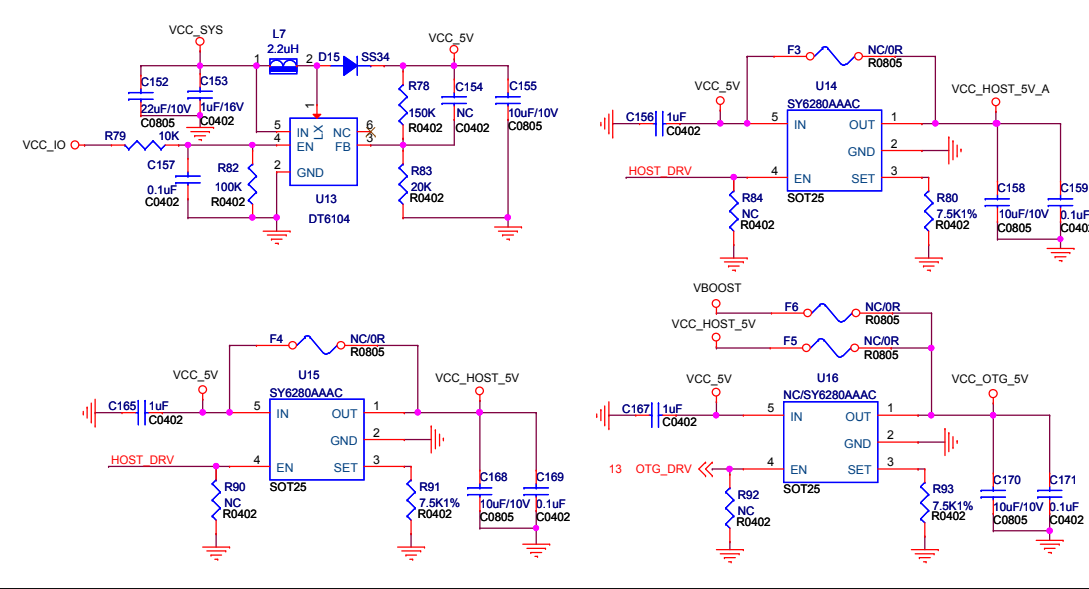

OTG PORT

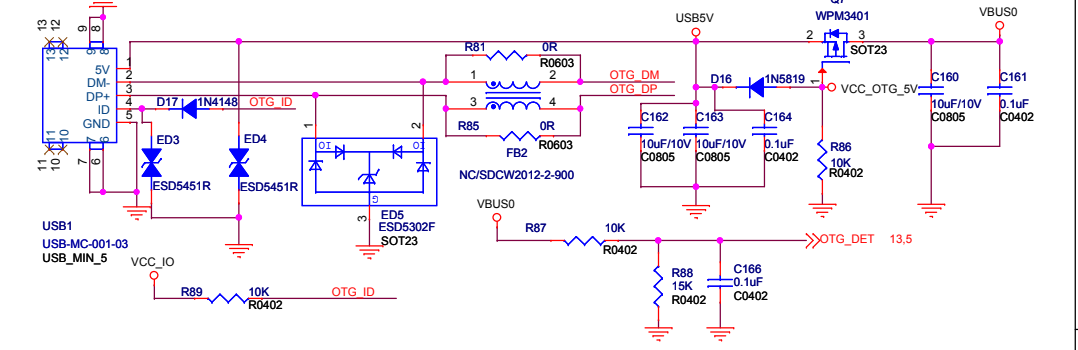

HUB

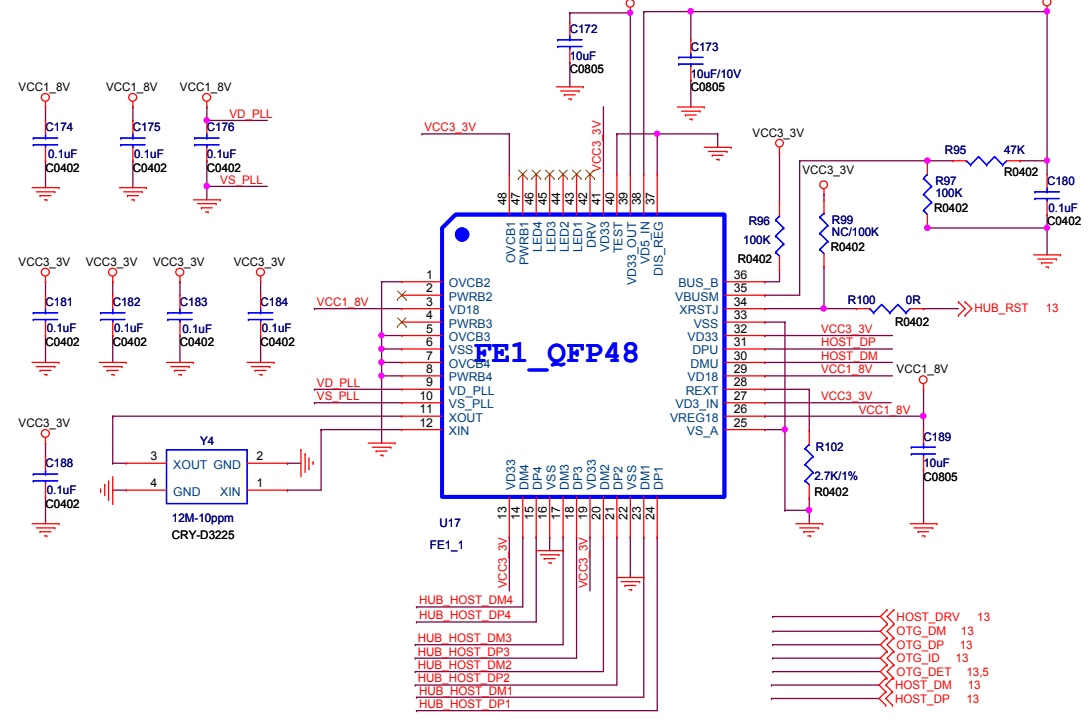

HOST PORT

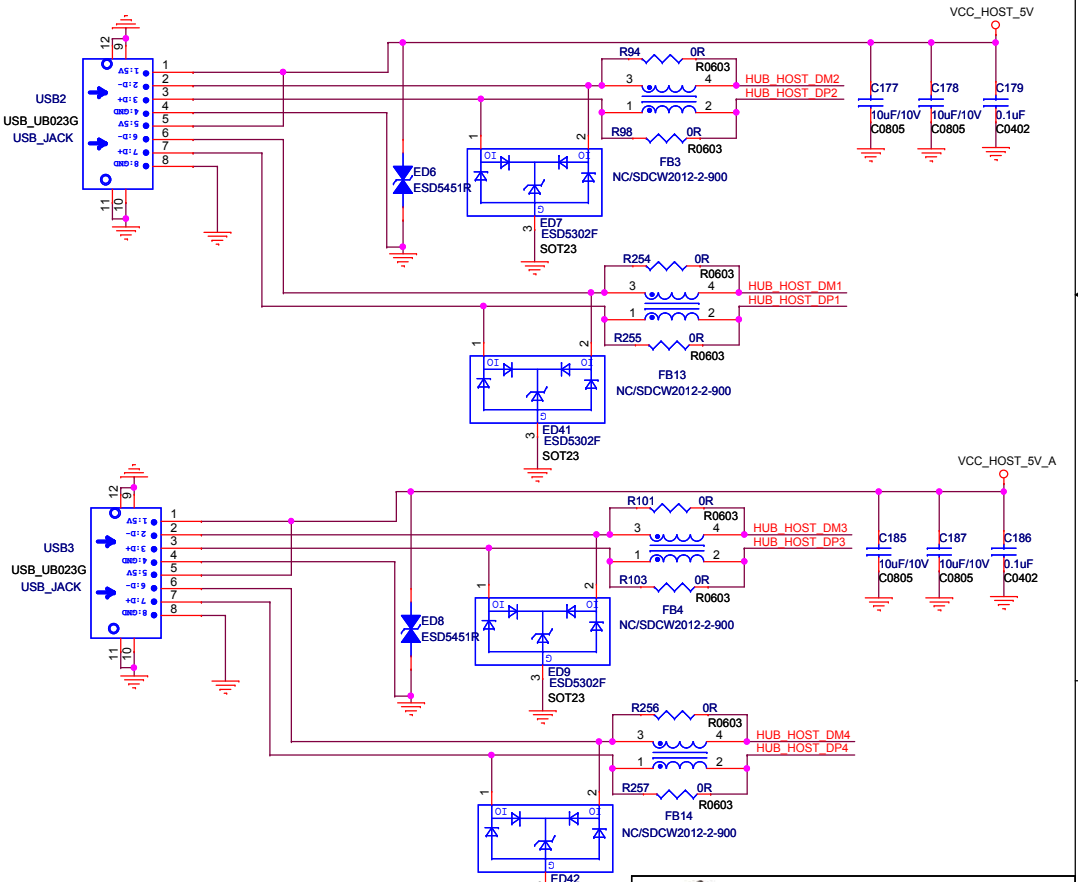



www.t-firefly.com

Title: USB Port	
File: FirePrime	
Create Date: Monday, June 01, 2015	Page Num: 5
Modify Date: Friday, May 13, 2016	Page Total: 13

TF CARD

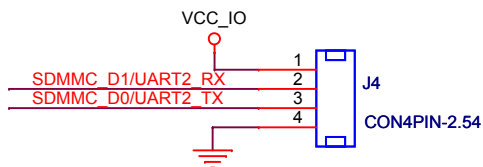
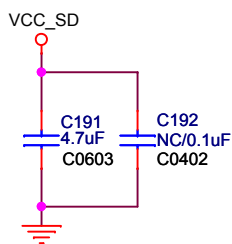
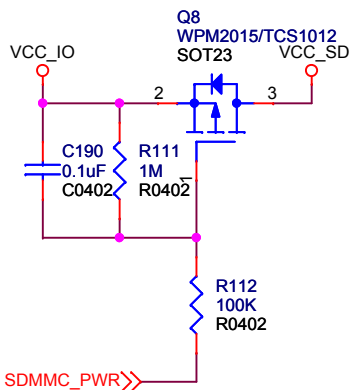
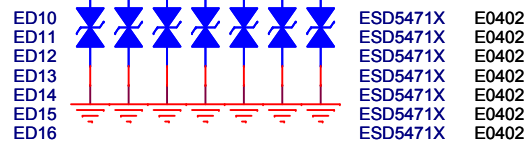
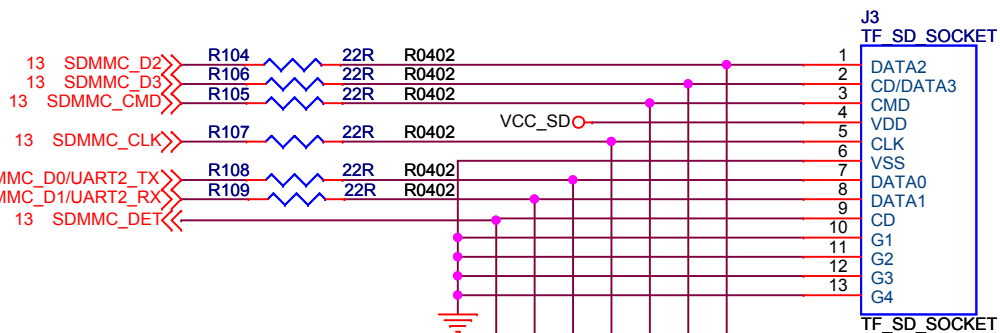

RTC

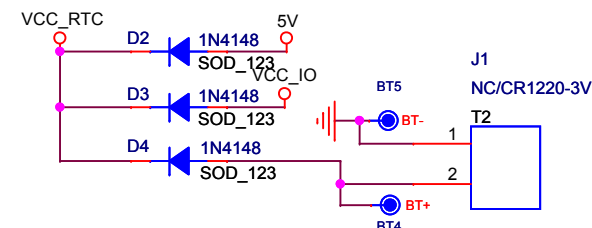
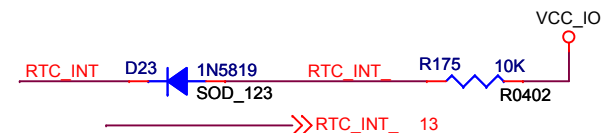
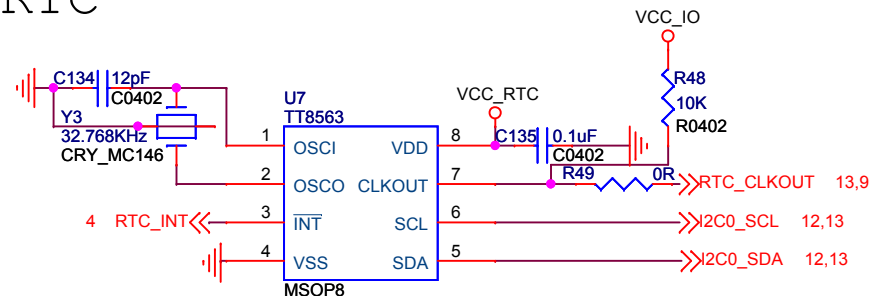

AT18

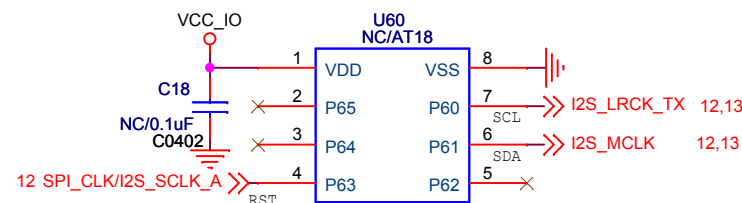

Title: TF card/RTC	
File: FirePrime	REV: 12
Create Date: Monday, June 01, 2015	Page Num: 6
Modify Date: Friday, May 13, 2016	Page Total: 13

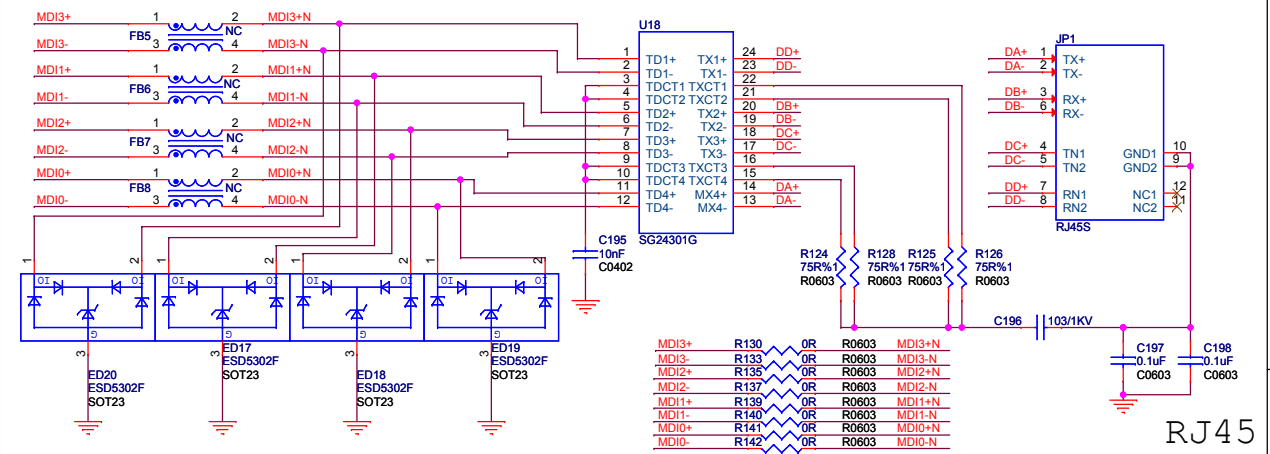
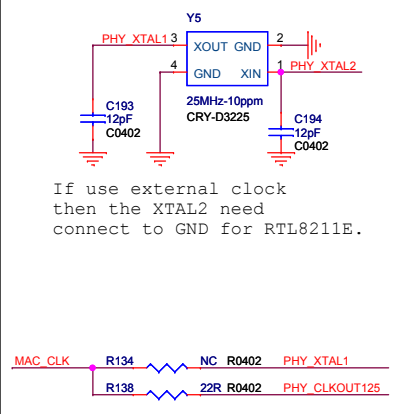
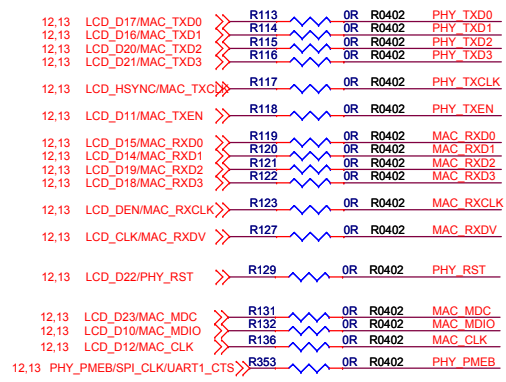

PHY

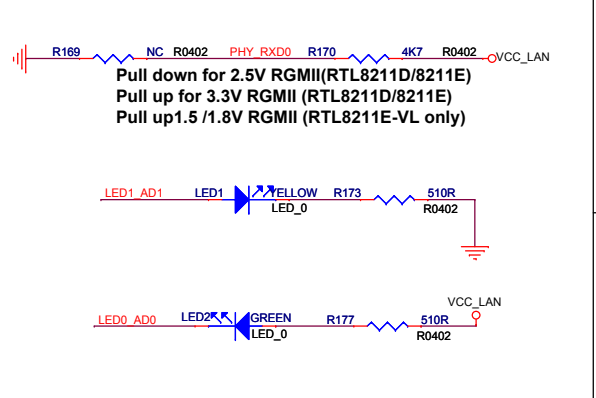
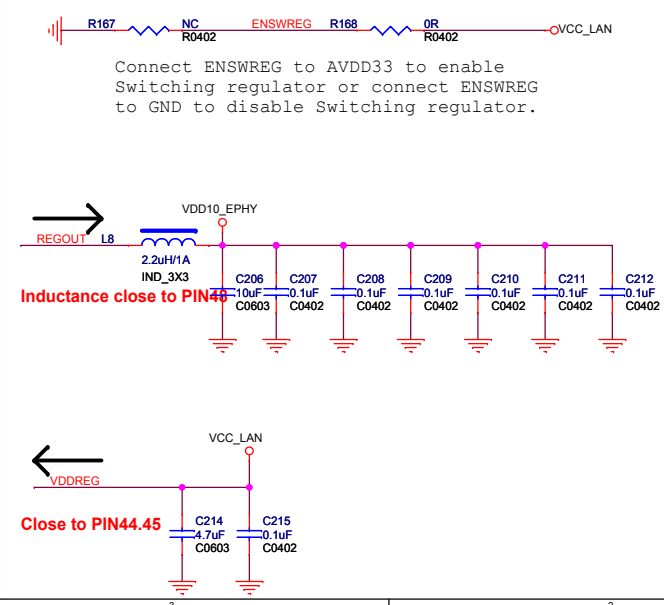
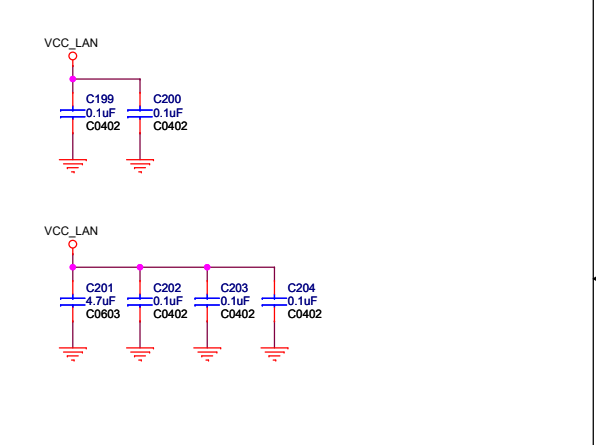
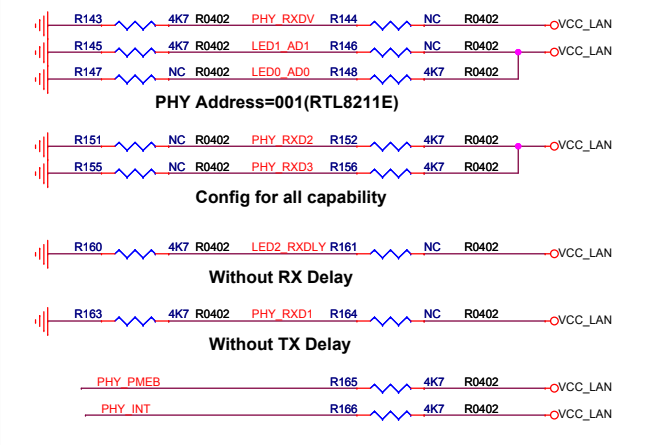
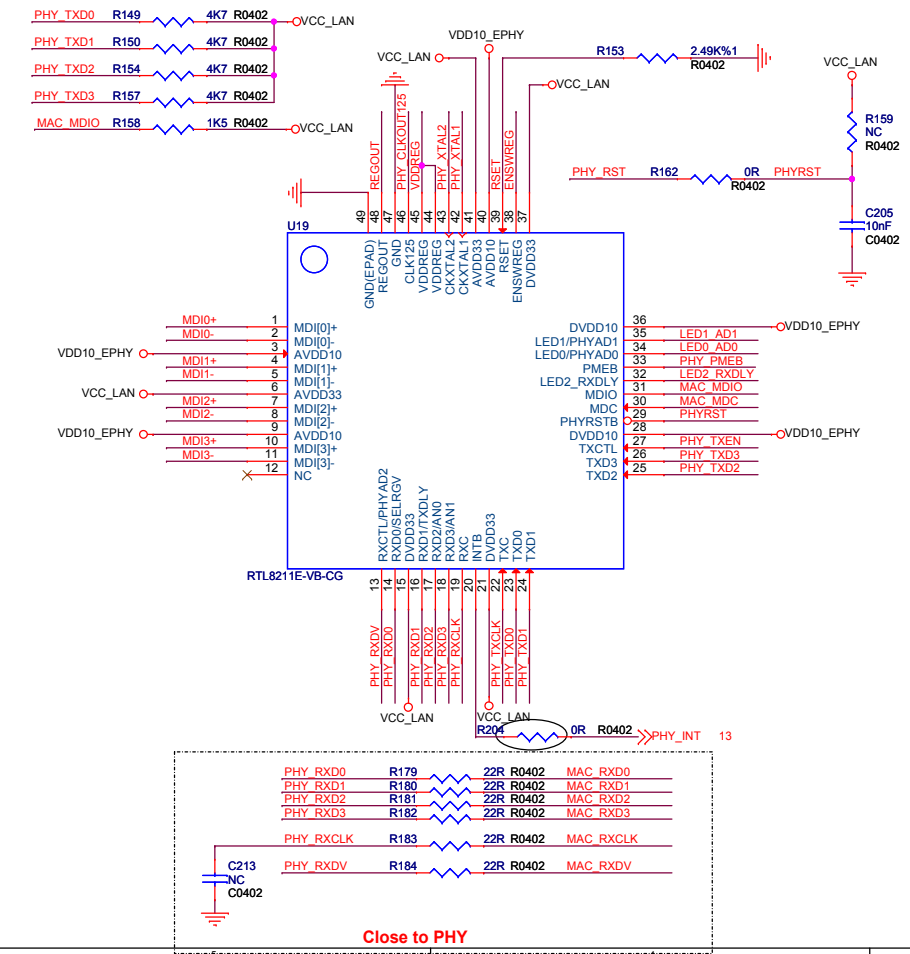

www.t-firefly.com

Title: 10/100/1000M-PHY

File: FirePrime

REV: 12

Create Date: Monday, June 01, 2015 Page Num: 7

Modify Date: Friday, May 13, 2016 Page Total: 13

2-Vrms Audio Line Driver

- >>CODEC_AOL 13
- >>CODEC_AOR 13
- >>CODEC_AOMS 13
- >>CODEC_AOM 13
- >>HP_DET 13
- >>MICIN-N 13
- >>MICIN-P 13
- >>VDAC_OUTP 13
- >>LINE_LIN 13
- >>LINE_RIN 13
- >>AUX_DET 13

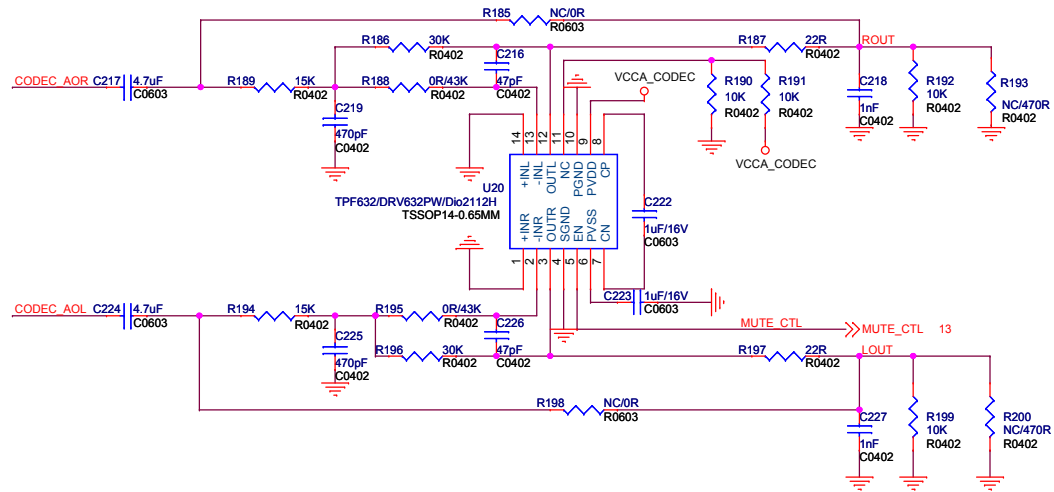
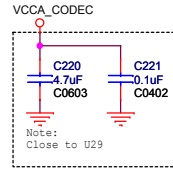

MIC

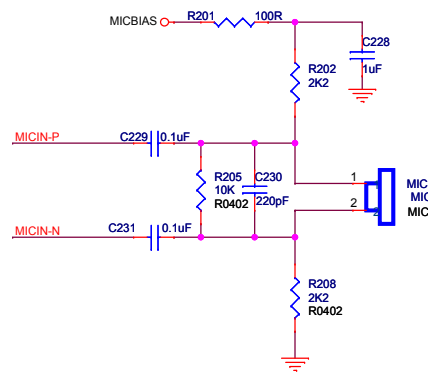

HEADPHONE

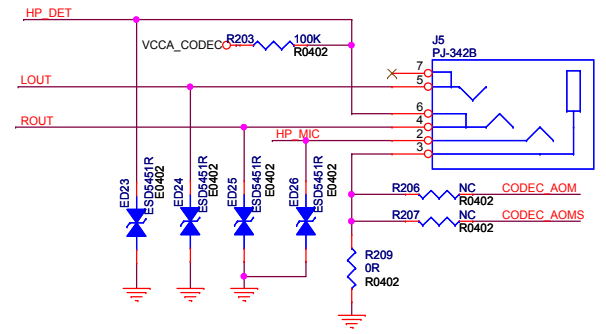
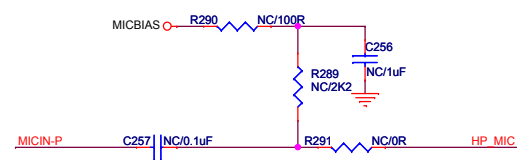

CVBS&LINE_OUT&LINE_IN

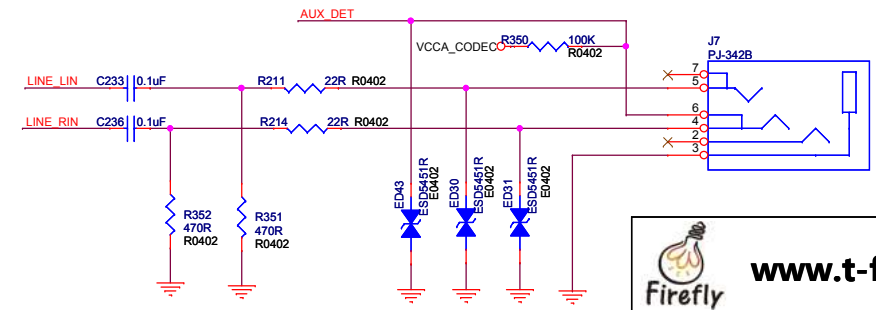
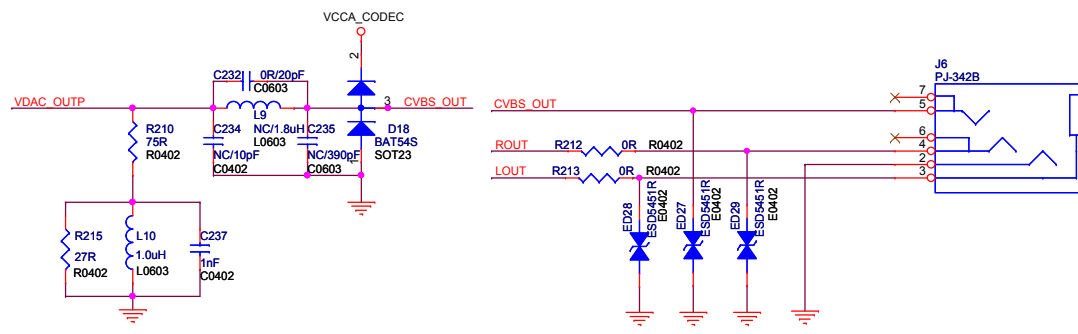

Title: AUDIO/CVBS		REV: 12
File: FirePrime		
Create Date: Monday, June 01, 2015	Page Num: 8	
Modify Date: Friday, May 13, 2016	Page Total: 13	

Note:
Adjusted the load capacitance according to the crystal specification.

50 Ohm RF trace

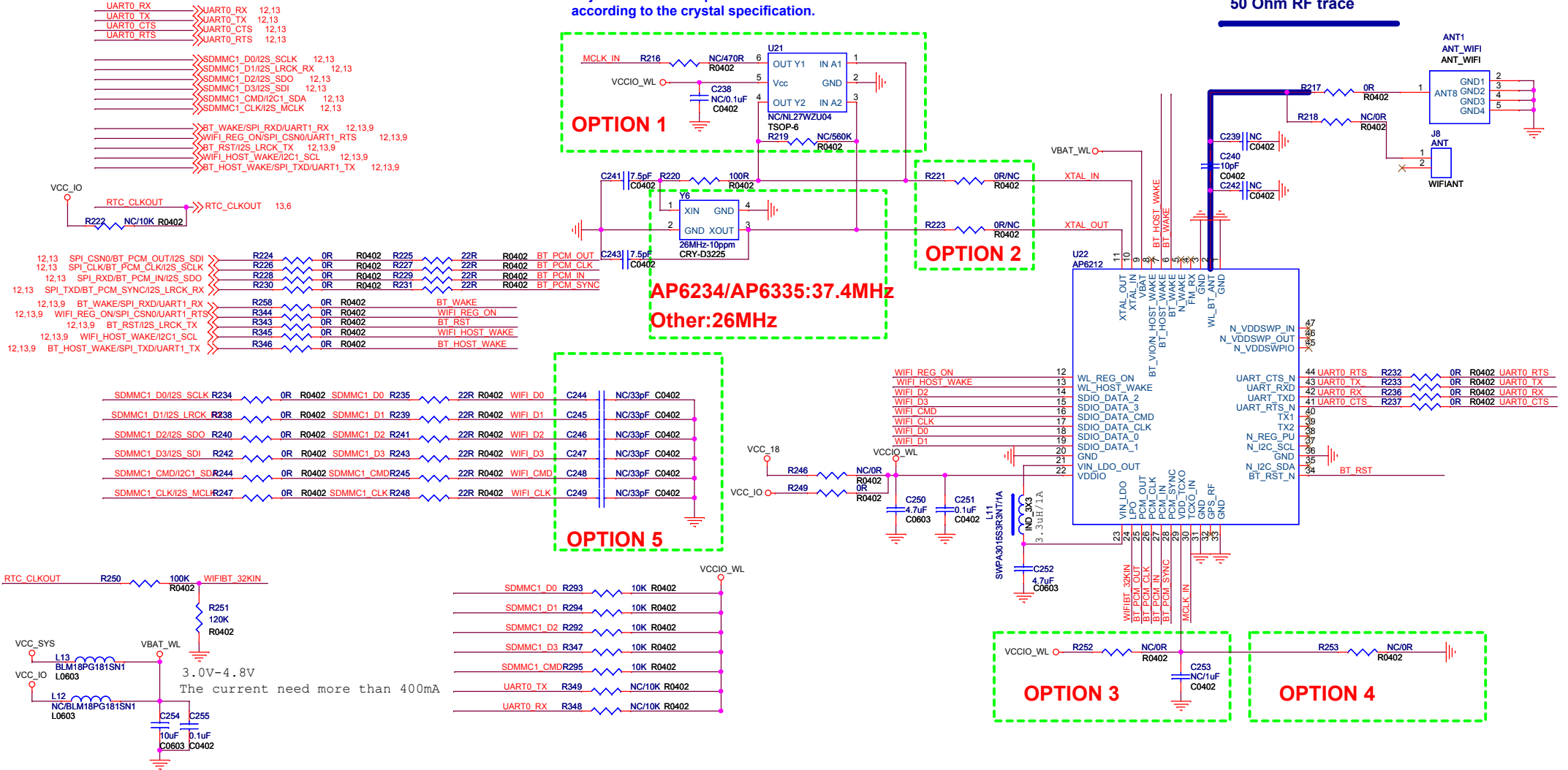

OPTION	WIFI				BT4.0	Crystals	VDDIO
	a	b/g/n	ac	5GHz			
AP6181		Yes				26MHz	1.71-3.6V
AP6210		Yes			Yes	26MHz	1.71-3.6V
AP6212		Yes			Yes	26MHz	1.71-3.6V
AP6330	Yes	Yes		Yes	Yes	26MHz	1.2-2.9V
AP6335 (Default)	Yes	Yes	Yes	Yes	Yes	37.4MHz	1.71-3.63V

OPTION	1	2	3	4	5
AP6181	No	Yes	No	No	No
AP6210	Yes	No	Yes	No	No
AP6212	No	Yes	No	No	No
AP6330	No	Yes	No	No	No
AP6335 (Default)	No	Yes	No	Yes	Yes

Note:
Yes: 框内要贴
No: 框内不贴

www.t-firefly.com

Title: WIFI/BT-AP6XXX
File: FirePrime
 Create Date: Monday, June 01, 2015
 Modify Date: Friday, May 13, 2016

REV: 12
 Page Num: 9
 Page Total: 13

HDMI_OUT

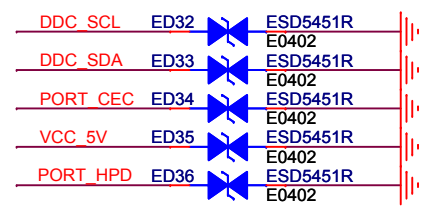
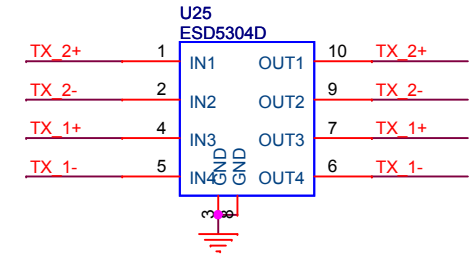
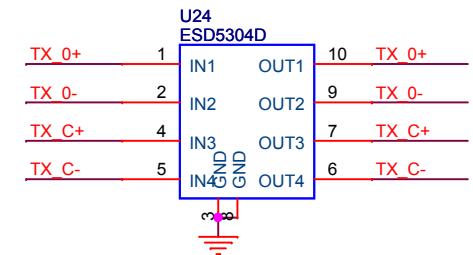
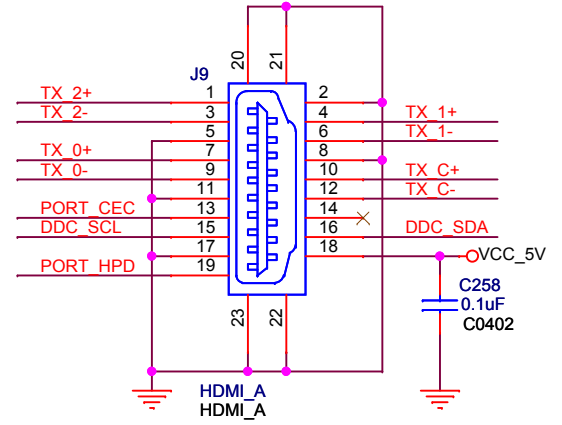
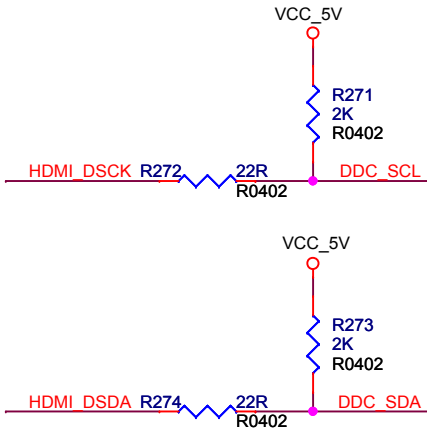
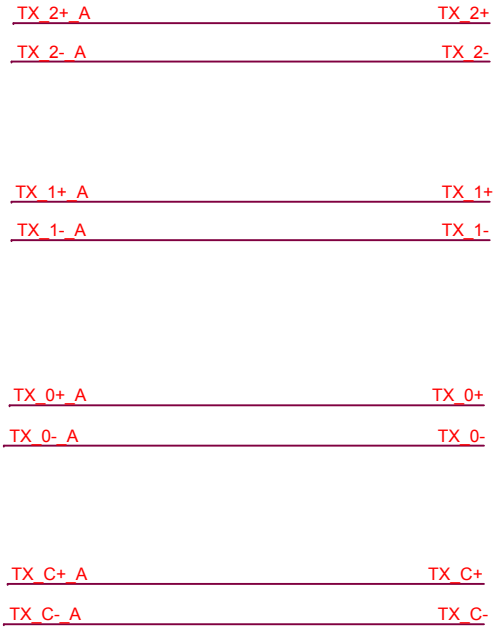
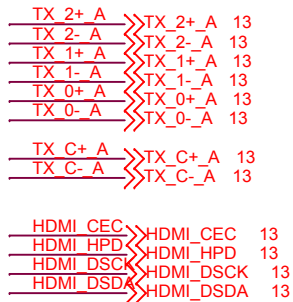
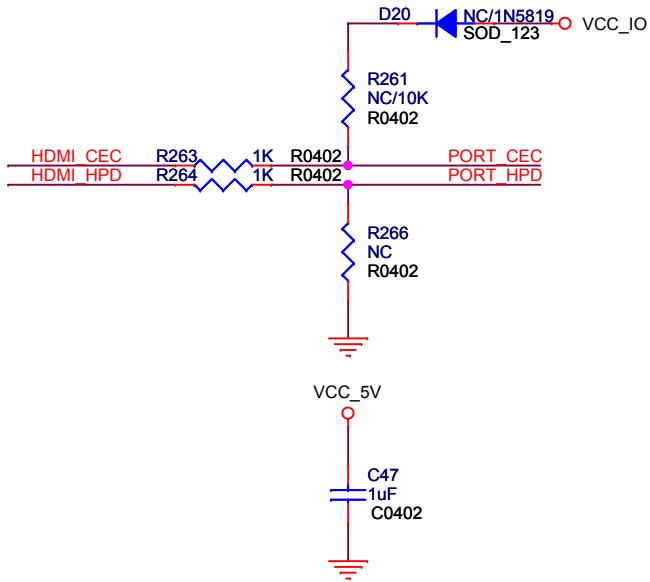

Title: HDMI OUT
File: FirePrime REV: 12
 Create Date: Monday, June 01, 2015 Page Num: 10
 Modify Date: Friday, May 13, 2016 Page Total: 13

SPDIF

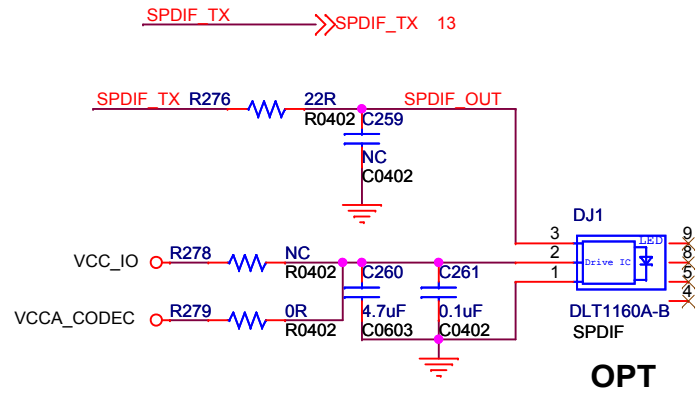

RESET

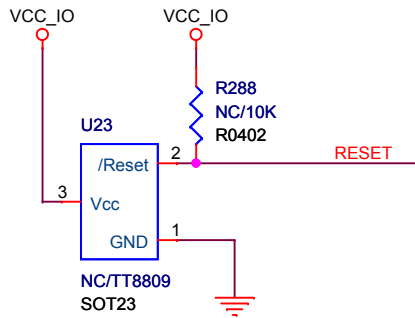

LED

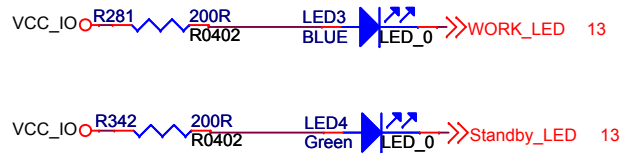

KEY

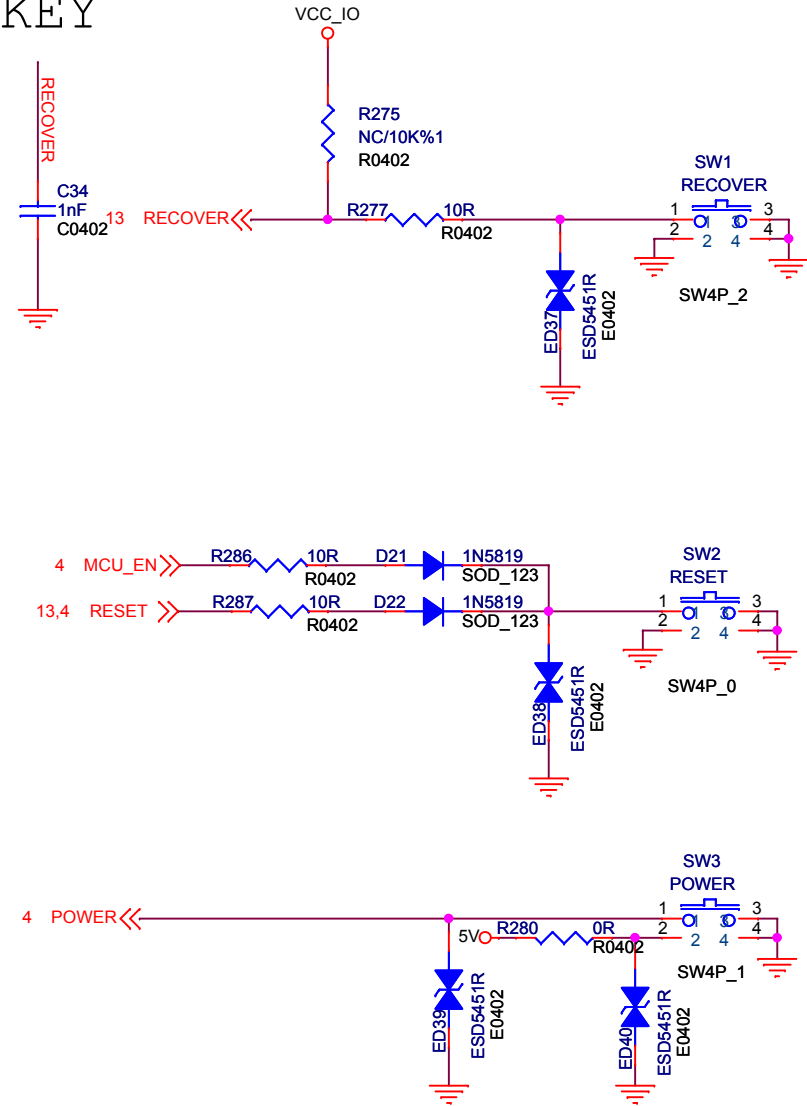

www.t-firefly.com

Title: SPDIF/KEY/LED

File: FirePrime

REV: 12

Create Date: Monday, June 01, 2015

Page Num: 11

Modify Date: Friday, May 13, 2016

Page Total: 13

Connector

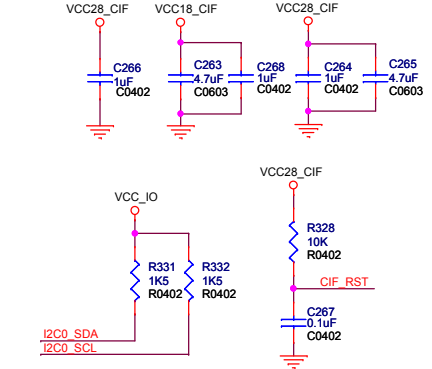
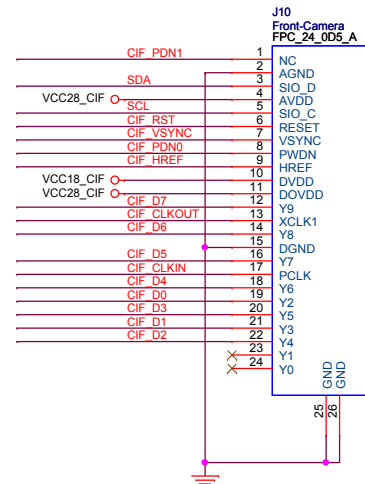
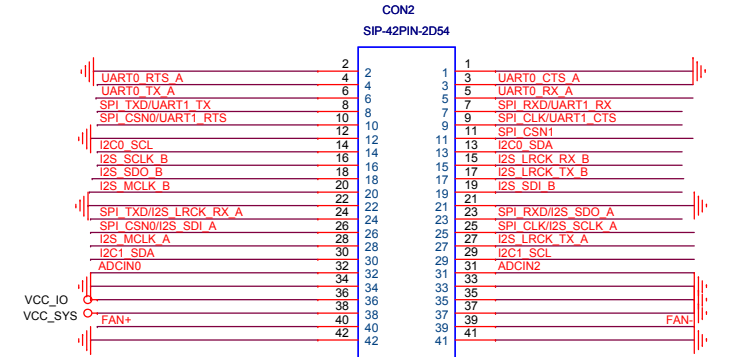
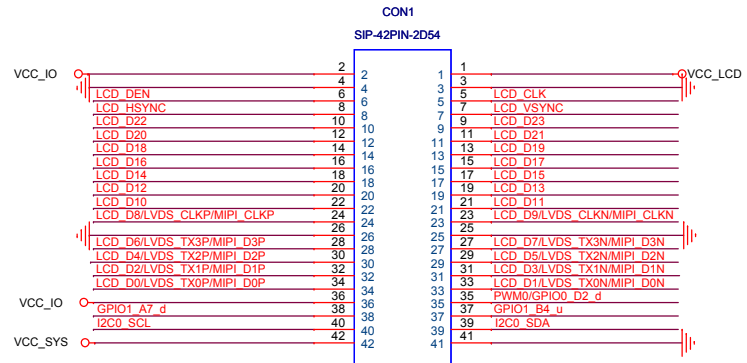
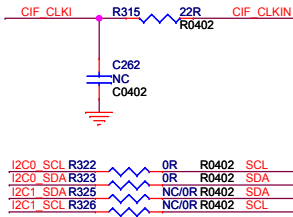
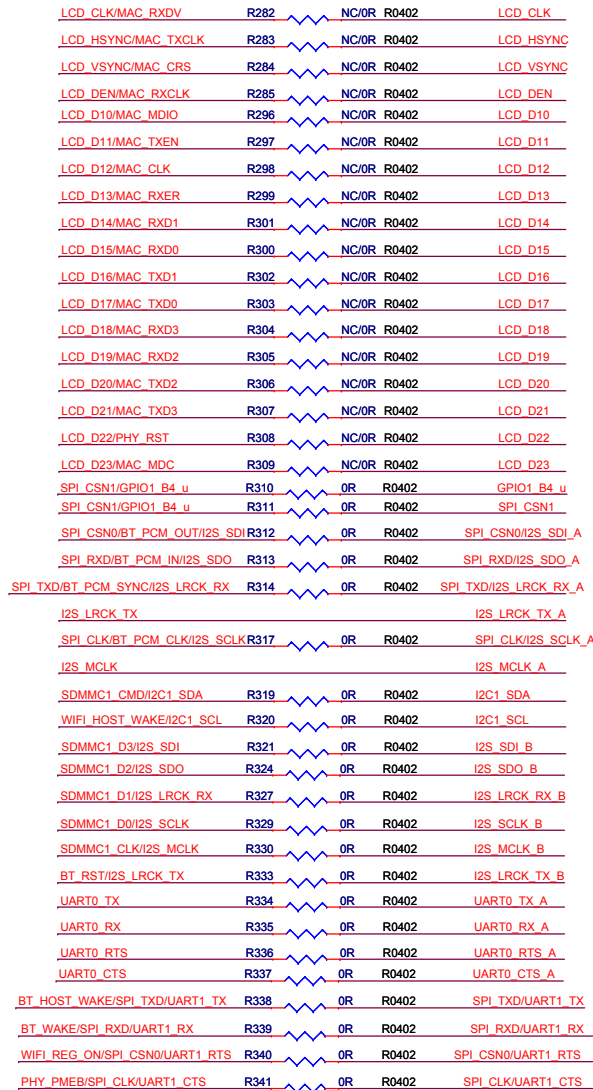
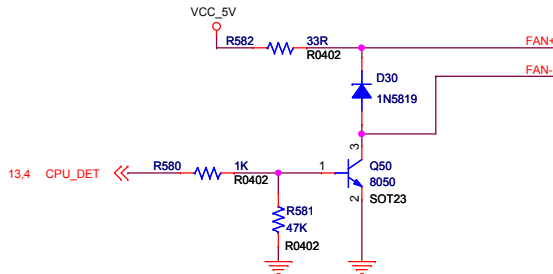
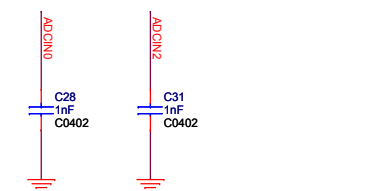
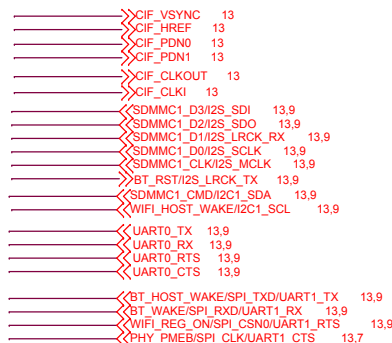
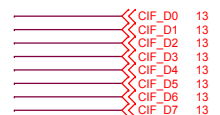
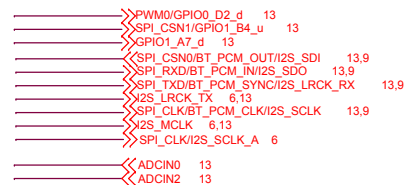
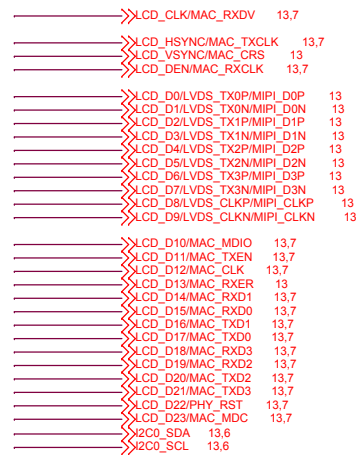

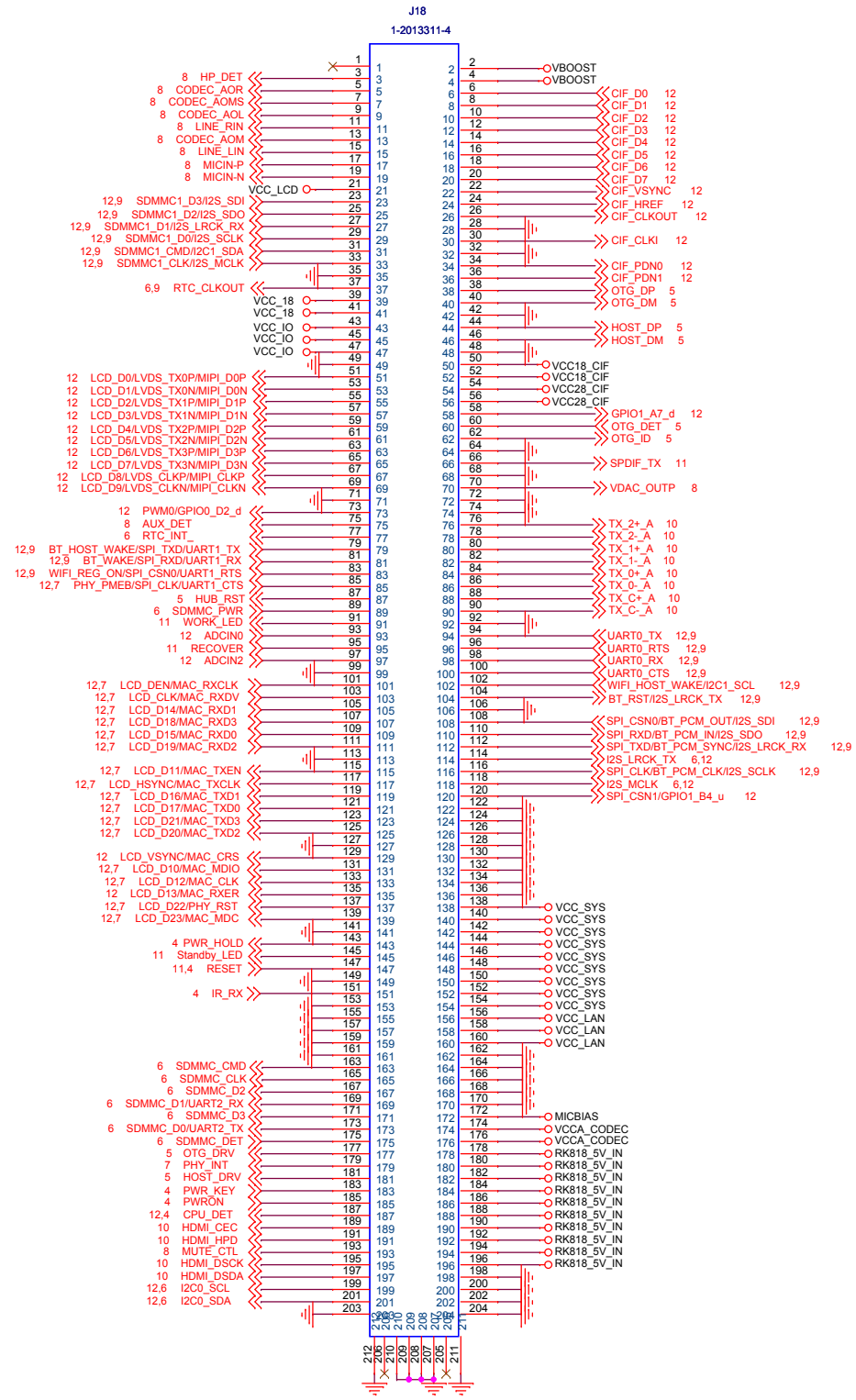

www.t-firefly.com
Title: Connector1
File: FirePrime
 Create Date: Monday, June 01, 2015
 Modify Date: Friday, May 13, 2016
 Page Num: 12
 Page Total: 13
 REV: 12

connector

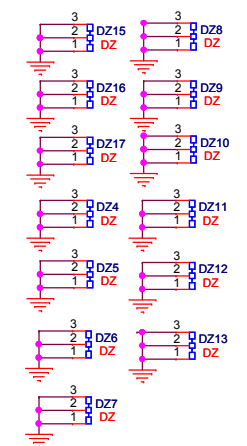

U51
Firefly
T-CHIP_LOGO

- MASK5
- MASK6
- MASK7
- MASK11
- MASK12
- MASK13





www.t-firefly.com

Title: Connector2	
File: FirePrime	REV: 12
Create Date: Monday, June 01, 2015	Page Num: 13
Modify Date: Friday, May 13, 2016	Page Total: 13